

# SI-COLO Series

## ▶ SI-COLO3-FIO-SP

- Big working range: typ. 1 mm ... 500 mm  
(depends on fiber optics and attachment optics)
- Big assortment of fiber optics and attachment optics  
(reflected or transmitted light)
- Up to 15 colors can be stored
- Super-bright white-light LED, 100 kHz modulated
- Color and gray scale detection
- Insensitive to outside light
- Brightness correction can be activated
- Several TEACH functions (via PC, PLC, or push button)
- RS232 interface (USB and Ethernet adapter available)
- Various evaluation algorithms can be activated
- Switching state display by means of 4 yellow LEDs
- 'Averaging' can be activated (from 1 up to over 32000 values)
- Material adaptation can be activated („Adaptive Control“)

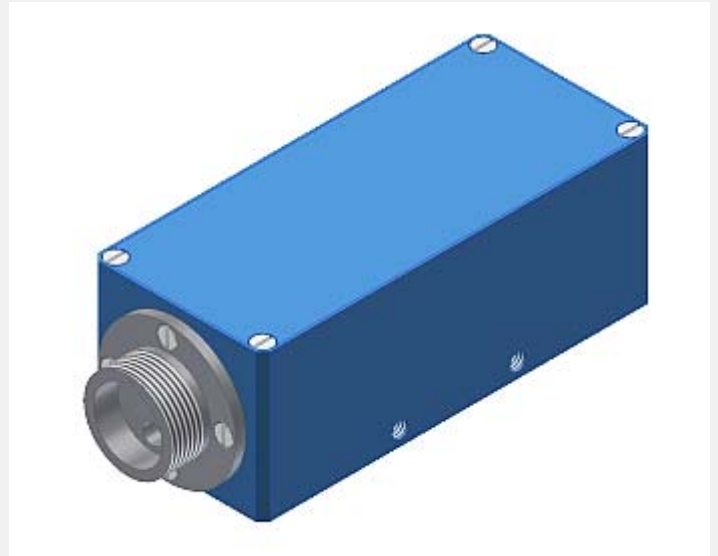

## Design

### Product name:

**SI-COLO3-FIO-SP**  
**SI-COLO3-FIO-SP-RA**

(incl. Windows® PC software SI-COLO3-Scope)

RA = Reduced Amplification

**Accessories:** (cf. pages 12-17)

**Fiber Optics**  
**Optical Frontends**  
**Fiber Optics Fixtures**

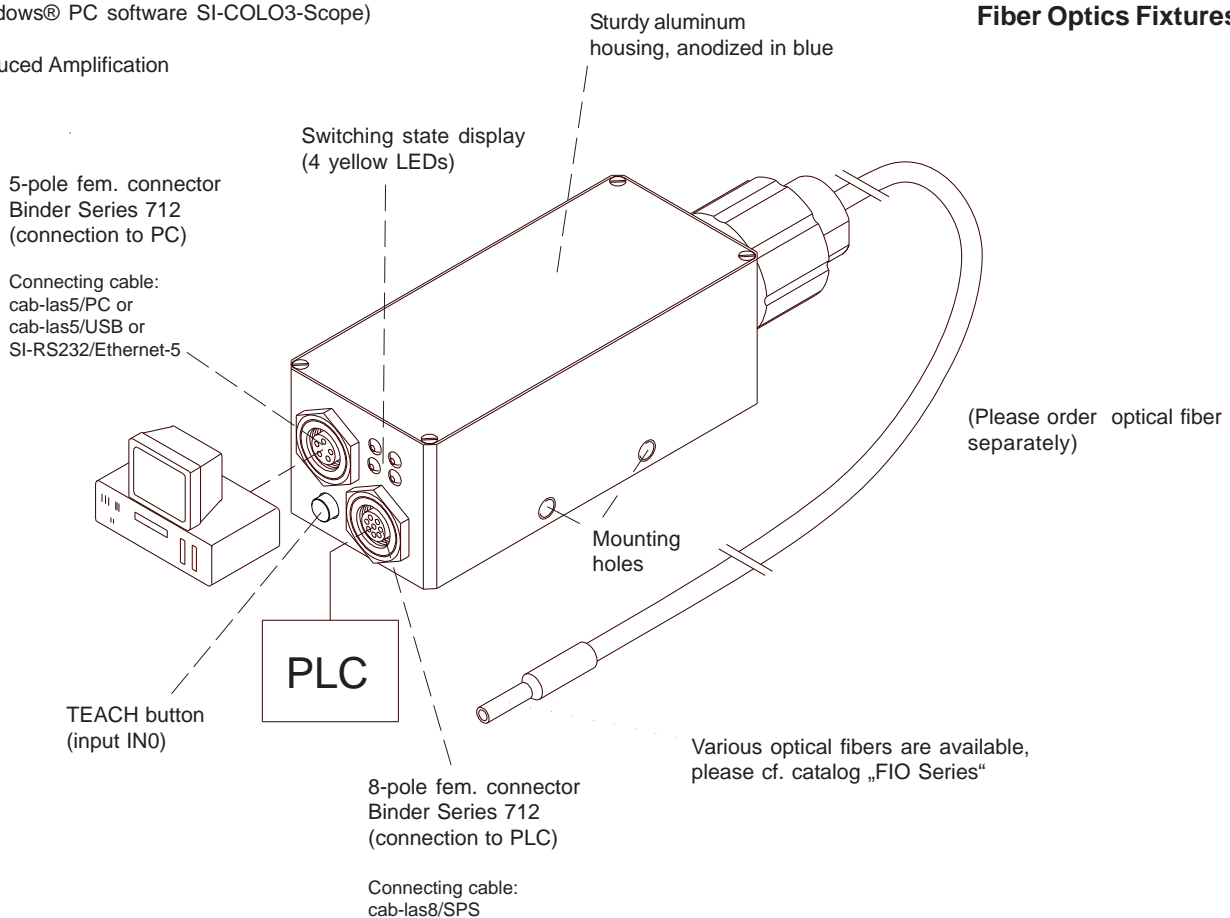



**Technical Data**

Model	SI-COLO3-FIO-SP
Light source	Super bright white-light LED, modulated 100 kHz
Size of light spot	circular: typ. Ø 0.2 mm ... Ø 20 mm or rectangular: typ. 3 mm x 0.5 mm ... 6 mm x 1 mm depends on fiber optics and attachment optics (cf. catalog FIO series)
Reproducibility	In the x,y color range 1 digit each with 12 bit A/D conversion
Object distance (measuring range)	with reflected light fiber optics: typ. 1 mm ... 500 mm (depends on fiber optics and attachment optics) with transmitted light fiber optics: typ. 10 mm ... 500 mm (depends on fiber optics and attachment optics)
Receiver	3-color filter detector
Alternating light operation	100 kHz
Ambient light	up to 5000 Lux
Type of protection	IP64
Current consumption	<180 mA
Interface	RS232, parameterizable under Windows®
Connector type	Connection to PLC: 8-pole female connector (Binder Series 712) Connection to PC: 5-pole female connector (Binder Series 712)
Connecting cables	to PLC: cab-las8/SPS or cab-las8/SPS-w to PC/RS232 interface: cab-las5/PC or cab-las5/PC-w to PC/USB interface: cab-las5/USB or cab-las5/USB-w, to PC/Ethernet interface: SI-RS232/Ethernet-5
EMC test acc. to	DIN EN 60947-5-2
Housing	Aluminum, anodized in blue Connector for optical fiber made of glass fiber reinforced plastic
Operating temperature range	-20°C ... +55°C
Storage temperature range	-20°C ... +85°C
Pulse lengthening	Adjustable under Windows® 0 ms ... 100 ms
Max. switching current	100 mA, short-circuit-proof
Switching frequency	Max. 1.6 kHz with 15 teach-in colors, max. 11.5 kHz with 1 teach-in color, max. 95 kHz with contrast detection
Input digital (1x)	IN0 (Pin 3), digital (0V/+24V) or teach button at the housing
Outputs digital (4x)	OUT0 ... OUT3 (Pin 4 ... 7): digital (0V/+24V), npn/pnp-able (bright-/dark-switching, can be switched)
Averaging	Over 32768 values max.
Voltage supply	+24VDC (± 10%), reverse polarity protected, overcurrent protected
Switching state display	Visualization by means of 4 yellow LEDs
Color memory capacity	non-volatile EEPROM with parameter sets for 15 colors max.
Optical fibers	various optical fibers are available (please cf. catalog FIO series)
TEACH button	for external teaching of color references via input IN0
Temperature drift X,Y	$\Delta X/\Delta T$ ; $\Delta Y/\Delta T$ typ. 0,3 digits/°C (< 0,01% / °C)



Dimensions

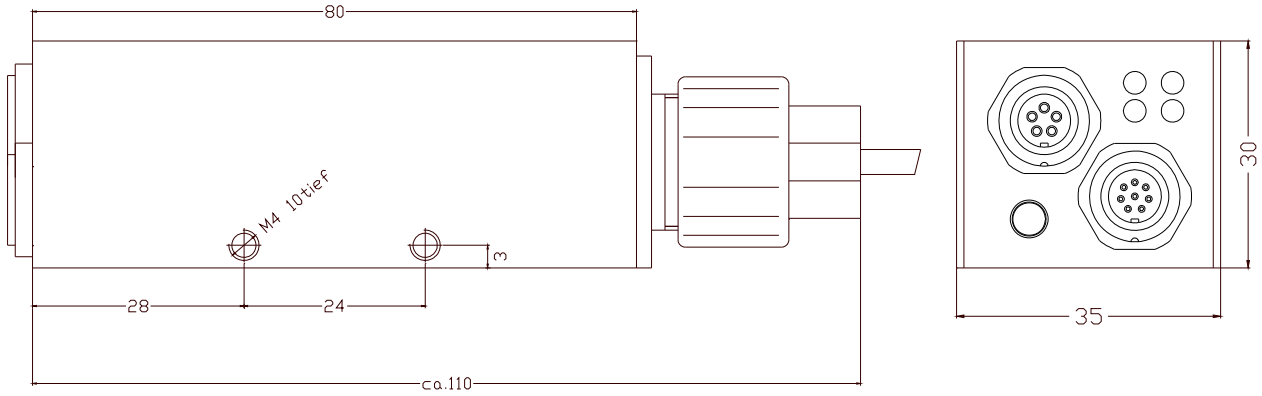

All dimensions in mm

## Connector Assignment

**Connection to PLC:****8-pole fem. connector Binder Series 712**

Pin: Color: Assignment:

1	white	GND (0V)
2	brown	+24VDC ( $\pm 10\%$ )
3	green	IN0
4	yellow	OUT0 (Digital 0: typ. 0...1V, Digital 1: typ. +Ub - 10%)
5	grey	OUT1 (Digital 0: typ. 0...1V, Digital 1: typ. +Ub - 10%)
6	pink	OUT2 (Digital 0: typ. 0...1V, Digital 1: typ. +Ub - 10%)
7	blue	OUT3 (Digital 0: typ. 0...1V, Digital 1: typ. +Ub - 10%)
8	red	not connected

**Connecting cable:**

cab-las8/SPS-(length)

cab-las8/SPS-w-(length) (angle type, 90°)

(standard length 2m)

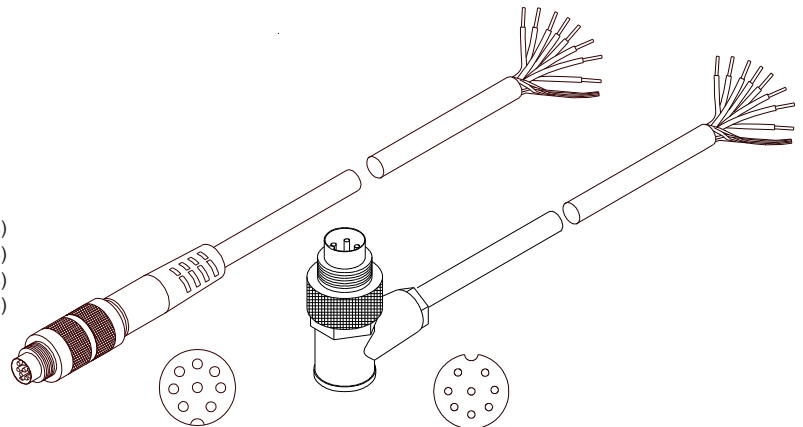
cab-las8/SPS-...  
(max. length 25m,  
outer jacket: PUR)cab-las8/SPS-w-...  
(max. length 25m,  
outer jacket: PUR)**Connection to PC:****5-pole fem. connector Binder Series 712**

Pin: Assignment:

1	GND (0V)
2	TxD
3	RxD
4	+24V (+Ub, OUT)
5	not connected

**Connection via RS232 interface at the PC:****Connecting cable:**

cab-las5/PC-(length)

cab-las5/PC-w-(length) (angle type 90°)

(standard length 2m)

**alternative:****Connection via USB interface at the PC:**

Connecting cable (incl. driver software):

cab-las5/USB-(length)

cab-las5/USB-w-(length) (angle type 90°)

(standard length 2m)

**alternative:****Connection to local network via Ethernet bus:**

Adapter (based on Lantronix XPortModul):

SI-RS232/Ethernet-5-(length)

(standard length 2m)

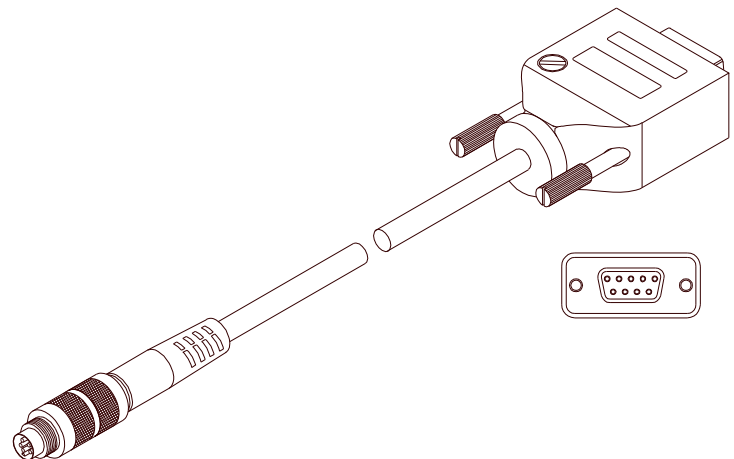
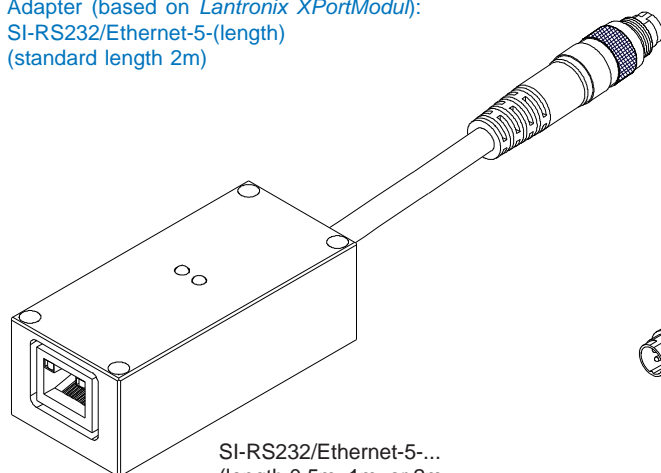
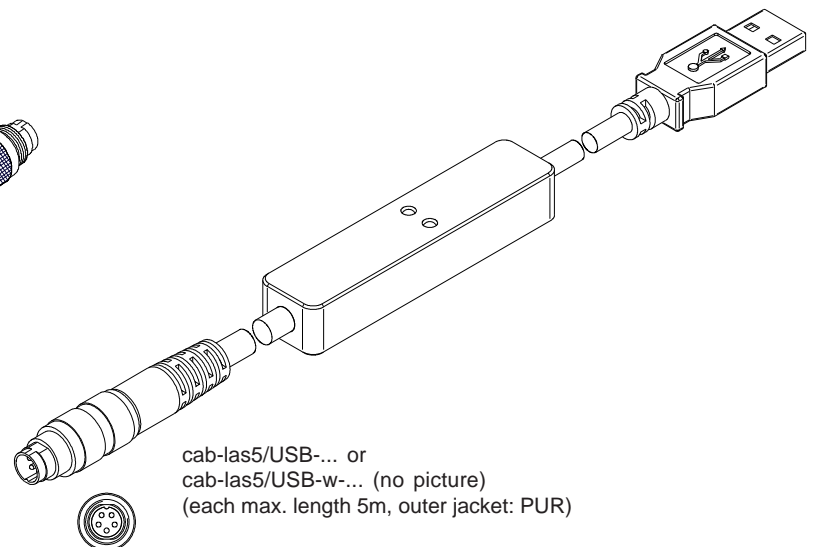
cab-las5/PC-...  
(max. length 10m, outer jacket: PUR) or  
cab-las5/PC-w-... (no picture)  
(max. length 5m, outer jacket: PUR)SI-RS232/Ethernet-5-...  
(length 0.5m, 1m, or 2m,  
outer jacket: PUR)cab-las5/USB-... or  
cab-las5/USB-w-... (no picture)  
(each max. length 5m, outer jacket: PUR)



## Measuring Principle

### Measuring principle of the SI-COLO3 color sensor:

The SI-COLO3 color sensor detects the radiation that is diffusely reflected by the target. The SI-COLO3 color sensor uses a white-light LED with adjustable power as a light source. A triple receiver for the RED, GREEN, and BLUE content of the light reflected from the target is used as a receiver. With the stepless adjustment of the integrated light source and the selectable gain of the receiver signal the sensor can be set to almost any surface.

The SI-COLO3 color sensor can be "taught" up to 15 colors. Tolerances can be set for every taught color. In X/Y INT or s/i M mode the tolerances represent a color cylinder in space. In X/Y/INT or s/i/M mode the tolerance represents a color sphere in space. Color evaluation according to s/i M and s/i/M uses the Lab calculation method. All the modes can be used in combination with various operating modes, among others "FIRST HIT" and "BEST HIT". The raw data are represented with 12 bit resolution. Color detection either operates continuously or is started by means of an external SPC trigger signal.

The respective detected color either is output as binary code at the 4 digital outputs, or it can be sent directly to the outputs, if only up to 4 colors are to be detected. Simultaneously the detected color code is visualised at the SI-COLO3 housing by means of 4 LEDs. With the TEACH button at the sensor housing the sensor can be taught up to 15 colors. For this purpose the corresponding evaluation mode must be set with the software. The TEACH button is connected in parallel to the input IN0 (green wire of cable cab-las8/SPS).

Through the RS232 interface parameters and measured values can be exchanged between the PC and the SI-COLO3 color sensor. All the parameters for color detection can be stored in the non-volatile EEPROM of the SI-COLO3 color sensor. When parameterization is finished the color sensor continues to operate with the current parameters in "stand alone" mode without a PC.

The sensors of the SI-COLO3 V6.4 series can be calibrated (white light balancing). Balancing can be performed to any white surface. A ColorChecker™ table with 24 color fields according to CIE standard is available as an alternative, and white light balancing or calibration can then be performed to one of the white fields.



## Parameterization

### Windows® user interface:

The Windows® user interface facilitates the teach-in process at the color sensor and supports the operator in the task of adjustment and commissioning of the color sensor.

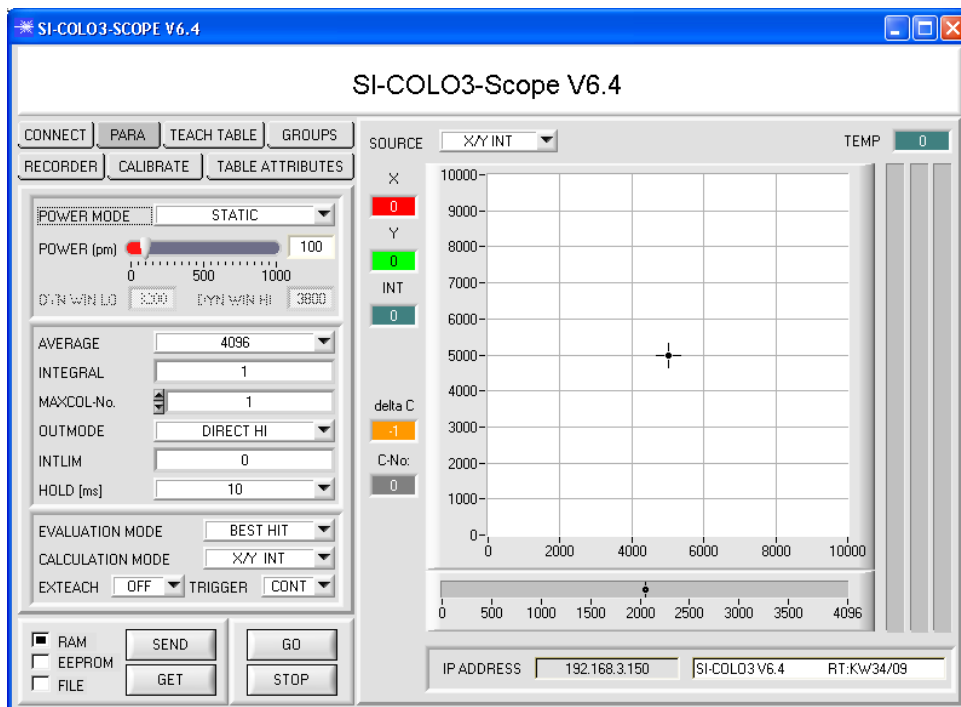

The RS232 interface (PARA tab) is used for setting parameters such as:

- POWER MODE:  
Light power of the white light LED
- AVERAGE:  
Averaging over max. 32768 values
- INTEGRAL:  
This function field is used to set the number of scan values (measurement values) over which the raw signal measured at the receiver is summed up. This integral function allows the reliable detection even of extremely weak signals.
- TRIGGER:  
Trigger continuous, external, or self trigger
- MAXCOL-No.:  
Number of colors to be checked
- GROUPS:  
Colors can be assigned to certain groups
- OUTMODE:  
Control of the digital outputs
- INTLIM:  
Setting of a minimum intensity limit for color evaluation
- HOLD:  
Pulse lengthening up to max. 100 ms

Under Windows® representation of the color value on a PC in numeric form and in a color chart, and representation of RGB values in a time chart. In addition the current RGB values are displayed as a bar chart.



**Parameterization**

**Offset calibration:**

To avoid an increase of the electronic offset when using the integral function (INTEGRAL parameter), this offset can be eliminated by way of offset calibration or zero-point calibration. The corresponding tab is password-protected to prevent inadvertent incorrect settings.

**Graphic display elements:**

**SOURCE:**

A click on the arrow button opens a selection field for the selection of a display mode in the graphic display window.

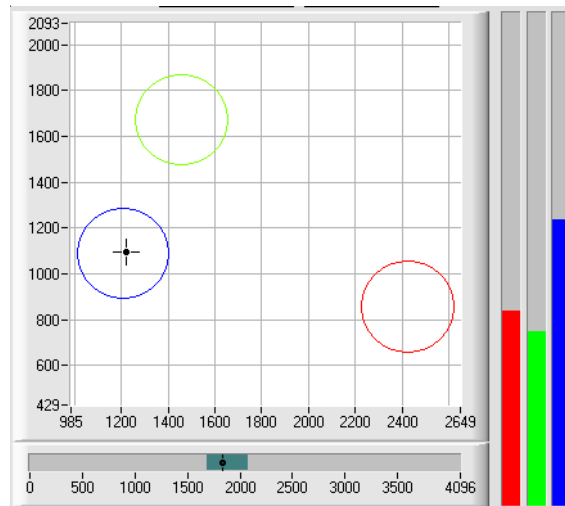

**X/Y INT bzw. s/i M:**

X/Y or s/i pairs are displayed in a zoomed graph. The intensity INT or M with the tolerance window set under No.: is shown directly below. Two-side view of the color cylinder in space.

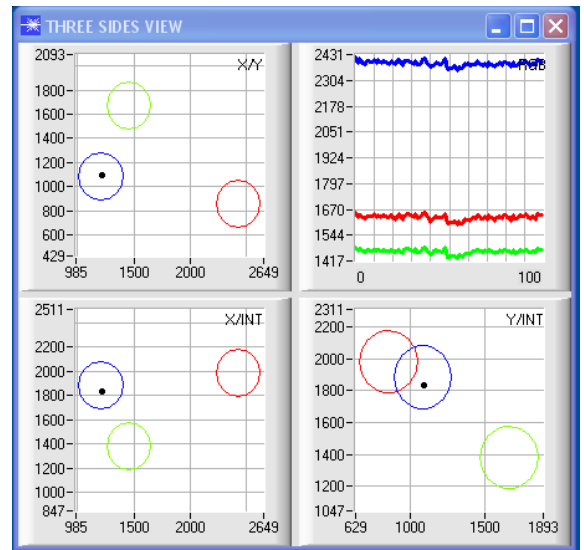

**X/Y/INT bzw. s/i/M:**

A panel opens that shows the taught color spheres and the current color position. For improved representation a three-side view with the graphs X/Y (s/i), X/INT (s/M) and Y/INT (i/M) was chosen.

**TEMP:**

This display shows the temperature prevailing in the sensor housing. The display DOES NOT show degrees Centigrade or Fahrenheit.

**delta C:**

This display (delta color) shows the deviation from a color hit, delta C corresponds with  $\Delta E$  that is calculated in a color measurement.

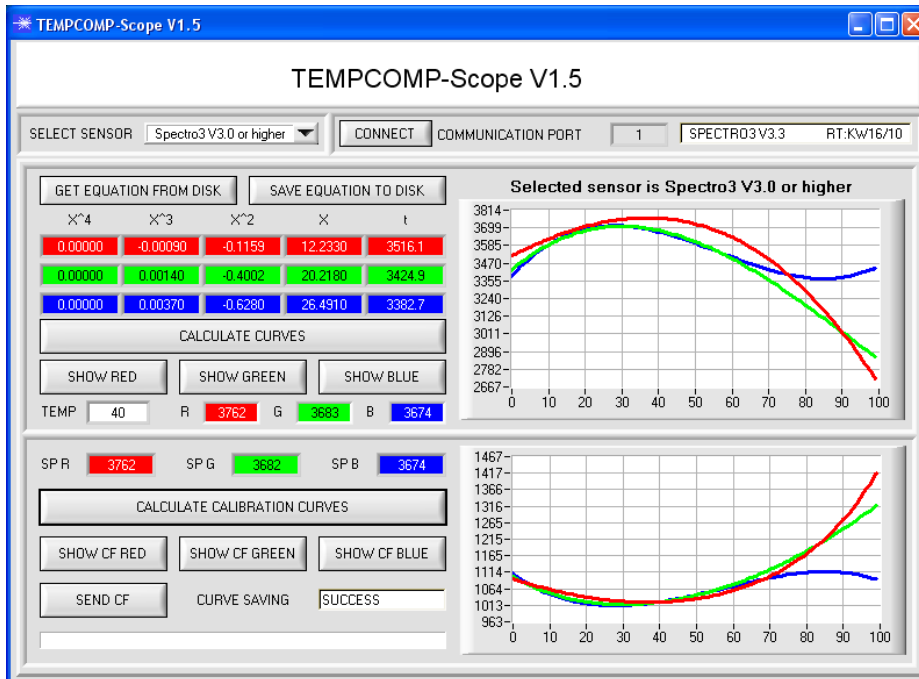

 Parameterization

**Operation of the TEMPCOMP-Scope software:**

If a firmware update should go wrong and the temperature characteristics that are stored in the EEPROM should be lost, these characteristics must be created anew. For this purpose you will need a file with the corresponding data. This file can be obtained from your supplier.

To perform temperature compensation please start the corresponding TEMPCOMP-Scope software that is included on the supplied CD. Please make sure that you have a functioning sensor connection. It may be necessary to select the connection with CONNECT. Set the correct sensor under SELECT SENSOR, if this is not done automatically.

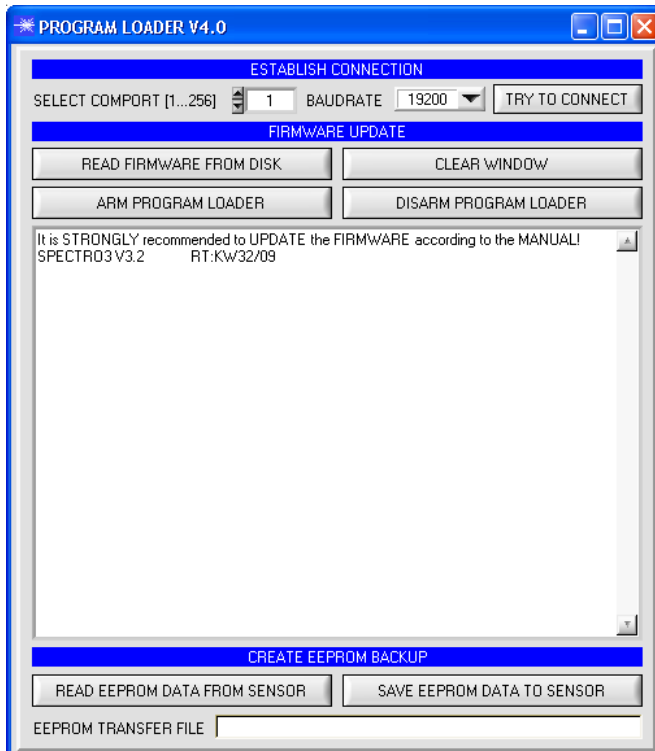
 Firmware Update

**Firmware Update by means of the software Program Loader:**

The software „Program Loader“ allows the user to perform an automatic firmware update. The update will be carried out through the RS232 interface.

An initialisation file (xxx.ini) and a firmware file (xxx.elf.S) are required for performing a firmware update. These files can be obtained from your supplier. In some cases an additional firmware file for the program memory (xxx.elf.p.S) is also needed, and this file will be automatically provided together with the other two files.

A plausibility check is performed after the initialisation file has been loaded with the Program Loader. If the initialisation file was changed or damaged, it will not be possible to perform a firmware update.

When the plausibility check is successfully completed, the instructions contained in the initialisation file will be carried out step by step.

The complete memory contents of the micro-controller in the sensor will be deleted in a firmware update. This means that both the program in the program memory and the data in the data memory will be lost.

The new firmware automatically writes the correct data to the program memory again.

However, the parameter settings, temperature curves, linearization curves, etc. that are stored in the data memory (EEPROM) will be deleted.

With the Program Loader V4.0 software the data will be saved in the EEPROM, and can be written back again after successful firmware update. For this purpose the software creates an EEPROM backup file.





**LED Display**

**LED display:**

The color code is visualised by way of 4 yellow LEDs at the housing of the SI-COLO2 color sensor. At the same time in the binary modus (OUT BINARY) the color code indicated on the LED display is output as 4-bit binary information at the digital outputs OUT0 to OUT3 of the 8-pin SI-COLO3/PLC socket.

The SI-COLO3 color sensor is able to process a maximum of 15 colors (color code 0 ... 14) in accordance with the corresponding rows in the COLOR TEACH TABLE. An "error" respectively a "not detected color" is displayed by the lighting of all LED (OUT0 .. OUT3 digital outputs are set to HIGH-level).

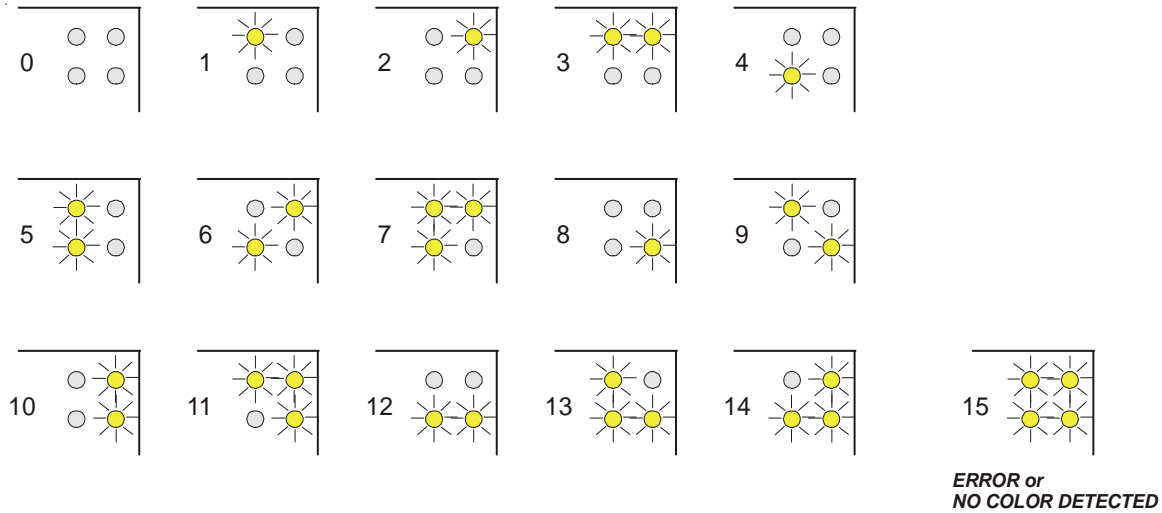

In the DIRECT mode (OUT DIRECT HI or OUT DIRECT LO) the maximum numbers of colors to be taught is 4 (color no. 0, 1, 2, 3).

If DIRECT HI is activated, the specially digital output is set to HI. If the current color does not correspond with any of the teach-in colors, color C-No = 0 is set, i.e. all digital outputs are set to LOW (no LED is lighting).

If DIRECT LO is activated, the specially digital output is set to LO, while the other 3 are set to HI. If the current color does not correspond with any of the teach-in colors, color C-No = 255 is set, i.e. all digital outputs are set to HIGH (all LED are lighting).

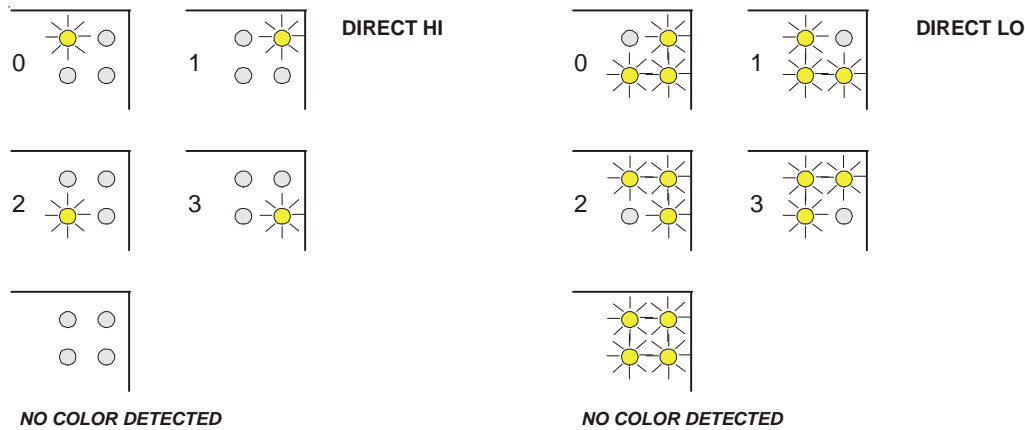





Diagrams

**Diagrams:** SPOT DIAMETER depending on distance

SPOT DIAMETER [distance], typ.

SI-COLO3-FIO-SP  
with fiber optics R-S-A1.1-(0.6)-1200-67°  
and attachment optics KL-4  
(fiber optics fixed at limit stop into attachment optics)

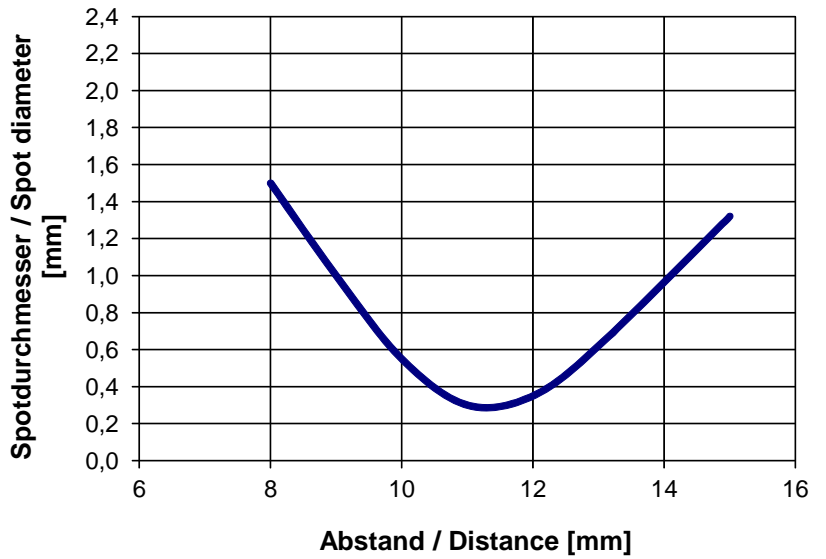

SPOT DIAMETER [distance], typ.

SI-COLO3-FIO-SP  
with fiber optics R-S-A1.1-(1.1)-1200-67°  
and attachment optics KL-4  
(fiber optics fixed at limit stop into attachment optics)

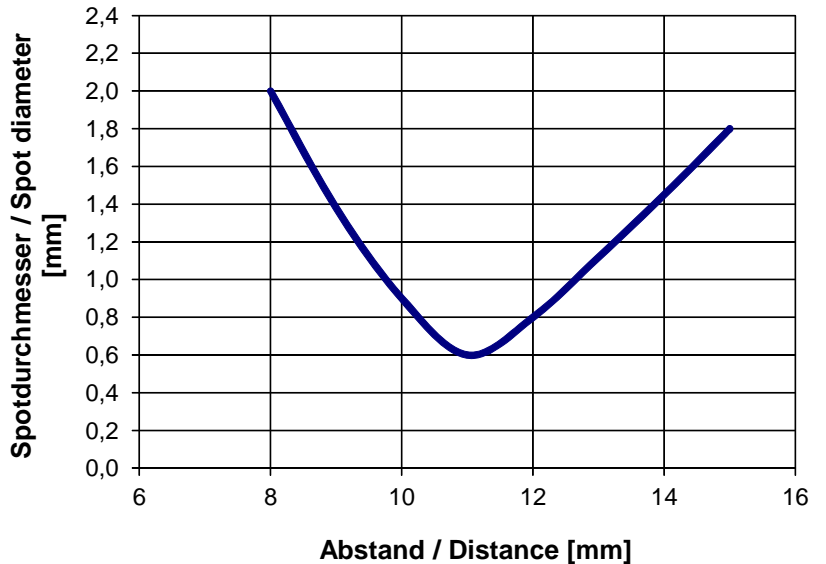

SPOT DIAMETER [distance], typ.

SI-COLO3-FIO-SP  
with fiber optics R-S-A1.1-(1.5)-1200-67°  
and attachment optics KL-4  
(fiber optics fixed at limit stop into attachment optics)

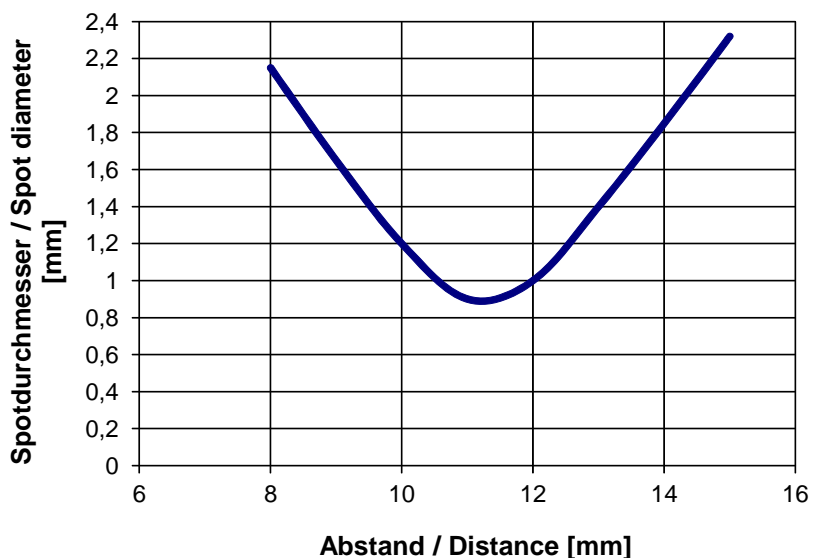



Diagrams

**Diagrams:** SPOT DIAMETER depending on object distance

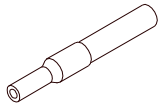

Faserbündel Ø 2.5 mm

SPOT DIAMETER [distance], typ.

SI-COLO3-FIO-SP  
with fiber optics R-P-A2.0-(2.5)-600-67°

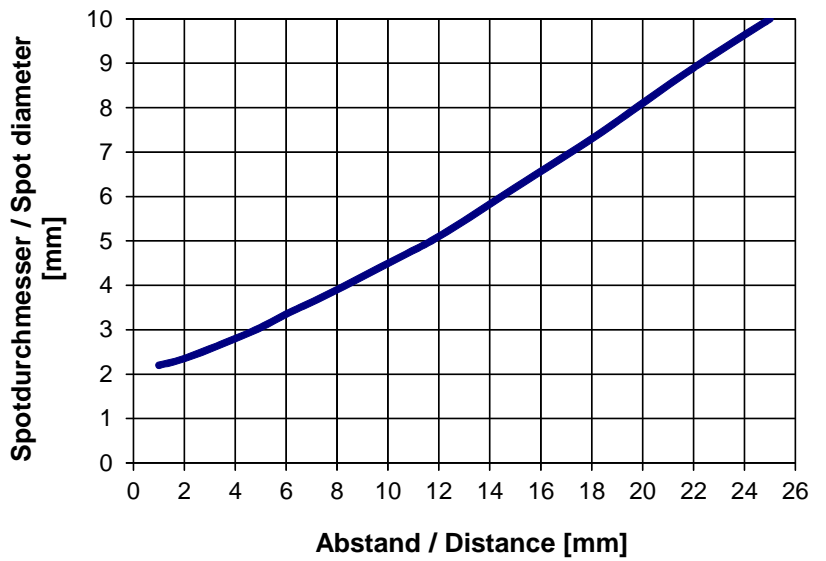

SPOT DIAMETER [distance], typ.

SI-COLO3-FIO-SP  
with fiber optics R-S-A2.0-(2.5)-1200-67°  
and attachment optics KL-3

(fiber optics is inner stop fixed to attachment optics)

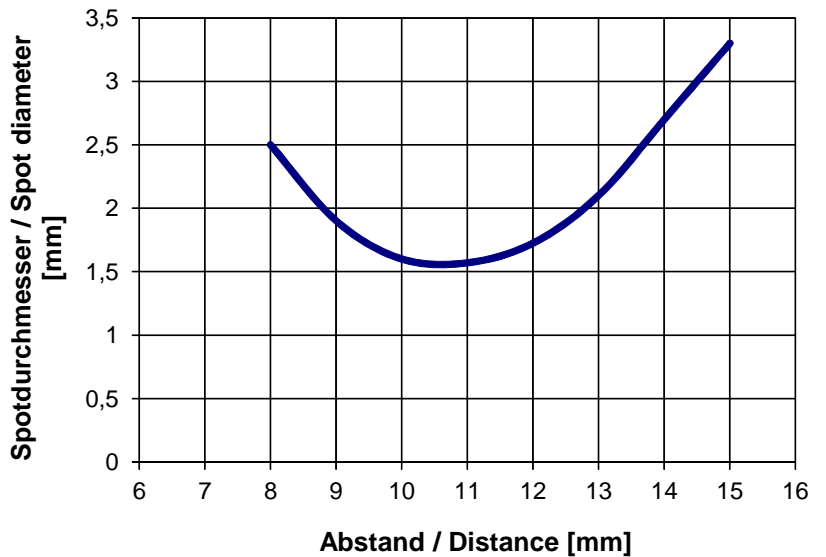

SPOT DIAMETER [distance], typ.

SI-COLO3-FIO-SP  
with fiber optics R-S-A2.0-(2.5)-1200-67°  
and attachment optics KL-M18-A2.0

(fiber optics is inner stop fixed to attachment optics)

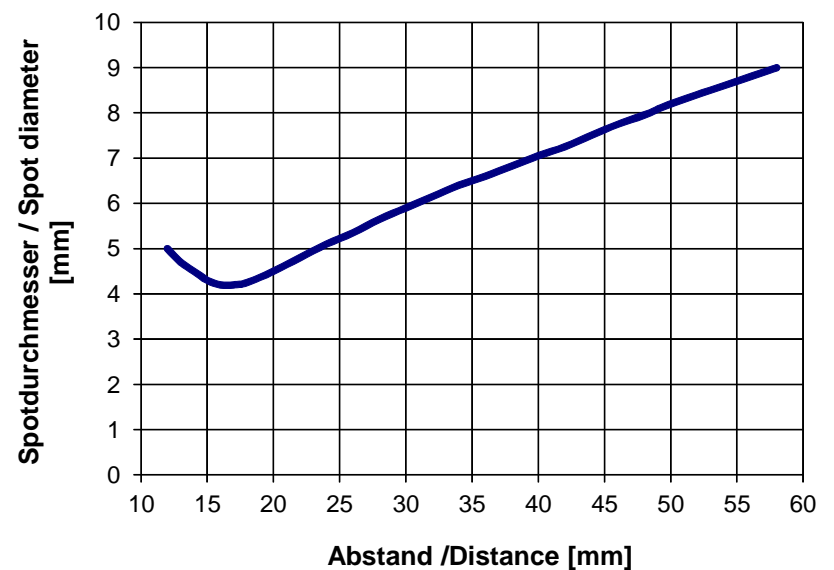



Diagrams

**Diagrams:** SPOT DIAMETER depending on object distance

SPOT DIAMETER [distance], typ.

SI-COLO3-FIO-SP  
with fiber optics R-S-A2.0-(2.5)-1200-67°  
and attachment optics KL-M34-A2.0  
(fiber optics is inner stop fixed to attachment optics)

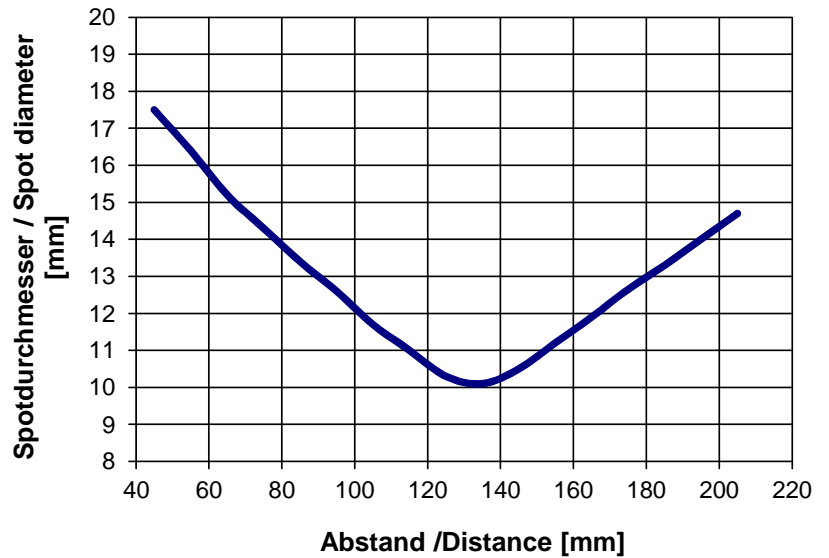

SPOT DIAMETER [distance], typ.

SI-COLO3-FIO-SP  
with fiber optics R-S-A3.0-(3.0)-1200-67°

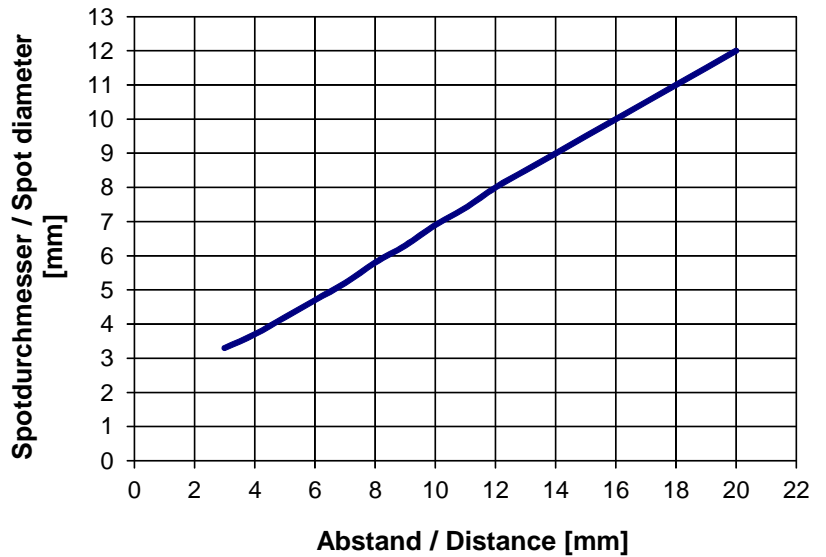

◆ short semiaxis  
● long semiaxis

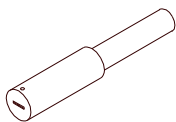

Fiber gap 6 mm x 1 mm

SPOT DIAMETER [distance], typ.

SI-COLO3-FIO-SP  
with fiber optics R-S-R2.1-(6x1)-1200-67°

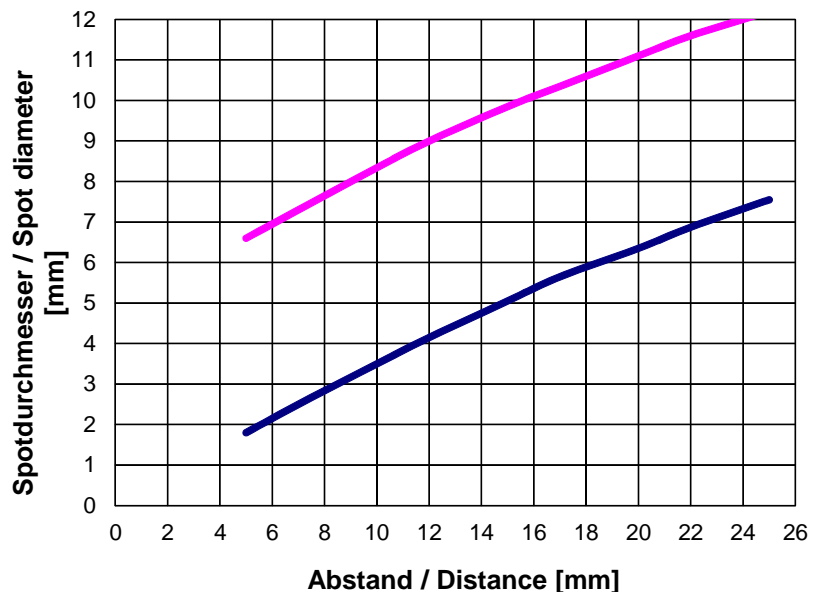



Fiber Optics

Field of use:

Optical fibers offer solutions for difficult tasks in optoelectronics. They can be used universally and allow flexible applications.

Advantages:

- Highest quality
- Selection from different fiber types
- Thermal stability
- Great variety of available standard sensor heads
- Special designs
- Various attachment optics available



Characteristics:

Light-conducting glass fibers are optical components that allow the transmission of light through any curved path based on the principle of total reflection.

The individual fiber is composed of high-break core glass and low-break cladding glass. The light beams entering the core glass within the critical angle are guided through the fiber by way of reflection at the core/cladding contact surfaces (step index fiber).

The highly flexible optical fibers are made of bundled individual glass fibers. The ends are each glued into a sensor head and a connector. The faces are optically polished. For protection against mechanical, chemical, or thermal destruction the optical fibers are provided with a corresponding protective sheath.

Order Code:

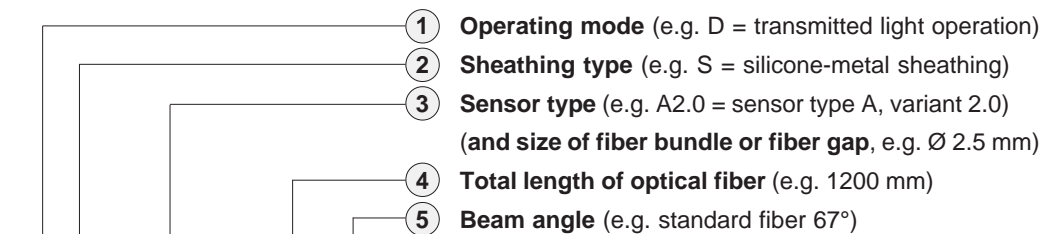

**D-S-A2.0-(2.5)-1200-67°**

Order code for optical fiber

(For detailed description of the various types of fiber optics, please cf. catalog „FIO Series“)

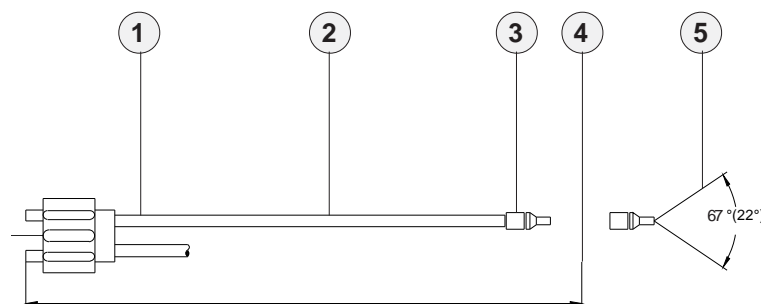

Dimensions of adapter

Attachment optics (e.g. focus lens, reflex optics, prism optics)

Fiber optics for reflex light operation

Fiber optics for transmitted light operation

Mounting hints

- cf. catalog FIO Series
- cf. catalog FIO Series
- cf. catalog FIO Series
- cf. catalog FIO Series
- cf. catalog FIO Series



Optical Frontends

Overview: Optical frontends for fiber optics



KL-1  
(A2.0)



KL-2  
(A2.0)



KL-3 (A2.0)  
KL-4 (A1.1)  
KL-5 (R1.1)  
KL-8 (R2.1)  
KL-9 (A3.0)



KL-90 (2x)  
(D-A2.0)



KL-D-2.5  
(D-A2.0)



KL-D-6  
(D-A2.0)



KL-D-14  
(D-A2.0)



KL-D-17  
(D-A2.0)



KL-D-20  
(D-A2.0)



KL-D-28  
(D-A2.0)



KL-D-40  
(D-A2.0)



KL-M8-A1.1



KL-M12-A1.1  
KL-M12-A2.0  
KL-M12-A3.0  
KL-M12-R1.1



KL-M12-XL-A1.1  
KL-M12-XL-A2.0  
KL-M12-XL-R1.1



KL-M18-A1.1  
KL-M18-A2.0  
KL-M18-A3.0  
KL-M18-R1.1  
KL-M18-R2.1



KL-M18-XL-A1.1  
KL-M18-XL-A2.0  
KL-M18-XL-A3.0  
KL-M18-XL-R1.1  
KL-M18-XL-R2.1



KL-M34-A1.1  
KL-M34-A2.0  
KL-M34-A3.0  
KL-M34-R1.1  
KL-M34-R2.1



KL-M34-XL-A1.1  
KL-M34-XL-A2.0  
KL-M34-XL-A3.0  
KL-M34-XL-R1.1  
KL-M34-XL-R2.1



KL-M34/62-A1.1  
KL-M34/62-A2.0  
KL-M34/62-A3.0  
KL-M34/62-R1.1  
KL-M34/62-R2.1



**Optical Frontends**

**Optical frontends for reflected light or transmitted light fiber optics:**

Part number:	Suitable for fiber optics type: (R, T = reflected light, D= transmitted light)	Characteristics:
KL-1 (2 pcs. necessary)	D-S-A2.0-(2.5)-...-67° or 22°	Transmitter/receiver distance typ. 50 mm ... 200 mm
KL-2	R-S-A2.0-(2.5)-...-67° or 22°	Transmitter/receiver distance max. 300 mm, beam divergency ± 7,5°
KL-2 (2 pcs. necessary)	D-S-A2.0-(2.5)-...-67° or 22°	Transmitter/receiver distance max. 300 mm, beam divergency ± 7,5°
KL-3	R-S-A2.0-(2.5)-...-67° or 22°	Working distance typ. 10 mm ... 20 mm
KL-3/30	R/D-S-A2.0-(2.5)-1200-67° <i>Special version*</i>	Working distance typ. 30 mm
KL-4	R-S-A1.1-(0.6)-...-67° or 22°	Working distance typ. 10 mm ... 15 mm
KL-4	R-S-A1.1-(1.1)-...-67° or 22°	Working distance typ. 10 mm ... 15 mm
KL-4	R-S-A1.1-(1.5)-...-67° or 22°	Working distance typ. 10 mm ... 15 mm
KL-5	R-S-R1.1-(3x0.5)-...-67° or 22°	Working distance typ. 8 mm ... 20 mm
KL-8	R-S-R2.1-(6x1)-...-67° or 22°	Working distance typ. 8 mm ... 25 mm
KL-8-N	R-S-R2.1-(6x1)-...-67° or 22°	Working distance typ. 8 mm ... 25 mm <i>with guide slot (adjustment aid)</i>
KL-9	R-S-A3.0-(3.0)-...-67° or 22°	Working distance typ. 8 mm ... 25 mm
KL-90 (2 pcs. necessary)	D-S-A2.0-(2.5)-...-67° or 22°	Working distance typ. 20 mm ... 100 mm - <i>prismatic optics</i>
KL-D-2.5	D-S-A2.0-(2.5)-...-67°	Working distance typ. 100 mm ... 500 mm
KL-D-6	D-S-A2.0-(2.5)-...-67°	Working distance typ. 100 mm ... 230 mm
KL-D-14	D-S-A2.0-(2.5)-...-67°	Working distance typ. 60 mm ... 120 mm
KL-D-14-T400	D-S-A2.0-(2.5)-1200-67°-T400	Working distance typ. 60 mm ... 120 mm <i>thermally stable up to 400°C</i>
KL-D-17	D-S-A2.0-(2.5)-...-67°	Working distance typ. 30 mm ... 80 mm
KL-D-20	D-S-A2.0-(2.5)-...-67°	Working distance typ. 10 mm ... 50 mm
KL-D-28	D-S-A2.0-(2.5)-...-67°	Working distance typ. 20 mm ... 50 mm
KL-D-30	D-S-A2.0-(2.5)-...-67°	Working distance typ. 20 mm ... 30 mm
KL-D-40	D-S-A2.0-(2.5)-...-67°	Working distance typ. 15 mm ... 25 mm
KL-M8-A1.1	R-S-A1.1-(1.5)-...-67°	Working distance typ. 8 mm ... 20 mm
KL-M12-A1.1	R-S-A1.1-(1.5)-...-67°	Working distance typ. 8 mm ... 40 mm
KL-M12-A2.0	R-S-A2.0-(2.5)-...-67°	Working distance typ. 8 mm ... 40 mm
KL-M12-A3.0	R-S-A3.0-(3.0)-...-67°	Working distance typ. 8 mm ... 40 mm
KL-M12-R1.1	R-S-R1.1-(3x0.5)-...-67° <i>Special version*</i>	Working distance typ. 8 mm ... 40 mm
KL-M12-XL-A1.1	R-S-A1.1-(1.5)-...-67°	Working distance typ. 20 mm ... 100 mm
KL-M12-XL-A2.0	R-S-A2.0-(2.5)-...-67°	Working distance typ. 20 mm ... 100 mm
KL-M12-XL-R1.1	R-S-R1.1-(3x0.5)-...-67°	Working distance typ. 20 mm ... 100 mm
KL-M12-XL-30°/30-A2.0	D-S-A2.0-30°/30-A2.0	Working distance typ. 20 mm ... 100 mm
KL-M18-A1.1	R-S-A1.1-(1.5)-...-67°	Working distance typ. 20 mm ... 60 mm
KL-M18-A2.0	R-S-A2.0-(2.5)-...-67°	Working distance typ. 20 mm ... 60 mm
KL-M18-A3.0	R-S-A3.0-(3.0)-...-67°	Working distance typ. 20 mm ... 60 mm
KL-M18-M5.0	T-S-M5.0-(5.0)-...-67° <i>Special version*</i>	Working distance typ. 20 mm ... 60 mm
KL-M18-M6.0	T-S-M6.0-(6.0)-...-67° <i>Special version*</i>	Working distance typ. 20 mm ... 60 mm
KL-M18-M8.0	T-S-M8.0-(8.0)-...-67° <i>Special version*</i>	Working distance typ. 20 mm ... 60 mm
KL-M18-R1.1	R-S-R1.1-(3x0.5)-...-67°	Working distance typ. 20 mm ... 60 mm
KL-M18-R2.1	R-S-R2.1-(6x1)-...-67°	Working distance typ. 20 mm ... 60 mm

\*Special version:

Version is different to the standard version (e.g. no standard fiber adapter) and therefore is suitable only for certain sensors or applications



Optical Frontends

## Optical frontends for reflected light or transmitted light fiber optics:

Part number:	Suitable for fiber optics type: (R, T = reflected light, D= transmitted light)	Characteristics:
KL-M18-XL-A1.1	R-S-A1.1-(1.5)-...-67°	Working distance typ. 10 mm ... 200 mm
KL-M18-XL-A2.0	R-S-A2.0-(2.5)-...-67°	Working distance typ. 10 mm ... 200 mm
KL-M18-XL-A3.0	R-S-A3.0-(3.0)-...-67°	Working distance typ. 10 mm ... 200 mm
KL-M18-XL-M5.0	T-S-M5.0-(5.0)-...-67° <i>Special version*</i>	Working distance typ. 10 mm ... 200 mm
KL-M18-XL-M6.0	T-S-M6.0-(6.0)-...-67° <i>Special version*</i>	Working distance typ. 10 mm ... 200 mm
KL-M18-XL-M8.0	T-S-M8.0-(8.0)-...-67° <i>Special version*</i>	Working distance typ. 10 mm ... 200 mm
KL-M18-XL-R1.1	R-S-R1.1-(3x0.5)-...-67°	Working distance typ. 10 mm ... 200 mm
KL-M18-XL-R2.1	R-S-R2.1-(6x1)-...-67°	Working distance typ. 10 mm ... 200 mm
KL-M34-A1.1	R-S-A1.1-(1.5)-...-67°	Working distance typ. 100 mm ... 250 mm
KL-M34-A2.0	R-S-A2.0-(2.5)-...-67°	Working distance typ. 100 mm ... 250 mm
KL-M34-A3.0	R-S-A3.0-(3.0)-...-67°	Working distance typ. 100 mm ... 250 mm
KL-M34-M5.0	T-S-M5.0-(5.0)-...-67° <i>Special version*</i>	Working distance typ. 100 mm ... 250 mm
KL-M34-M6.0	T-S-M6.0-(6.0)-...-67° <i>Special version*</i>	Working distance typ. 100 mm ... 250 mm
KL-M34-M8.0	T-S-M8.0-(8.0)-...-67° <i>Special version*</i>	Working distance typ. 100 mm ... 250 mm
KL-M34-R1.1	R-S-R1.1-(3x0.5)-...-67°	Working distance typ. 100 mm ... 250 mm
KL-M34-R2.1	R-S-R2.1-(6x1)-...-67°	Working distance typ. 100 mm ... 250 mm
KL-M34-XL-A1.1	R-S-A1.1-(1.5)-...-67°	Working distance typ. 50 mm ... 400 mm
KL-M34-XL-A2.0	R-S-A2.0-(2.5)-...-67°	Working distance typ. 50 mm ... 400 mm
KL-M34-XL-A3.0	R-S-A3.0-(3.0)-...-67°	Working distance typ. 50 mm ... 400 mm
KL-M34-XL-M5.0	T-S-M5.0-(5.0)-...-67° <i>Special version*</i>	Working distance typ. 50 mm ... 400 mm
KL-M34-XL-M6.0	T-S-M6.0-(6.0)-...-67° <i>Special version*</i>	Working distance typ. 50 mm ... 400 mm
KL-M34-XL-M8.0	T-S-M8.0-(8.0)-...-67° <i>Special version*</i>	Working distance typ. 50 mm ... 400 mm
KL-M34-XL-R1.1	R-S-R1.1-(3x0.5)-...-67°	Working distance typ. 50 mm ... 400 mm
KL-M34-XL-R2.1	R-S-R2.1-(6x1)-...-67°	Working distance typ. 50 mm ... 400 mm
KL-M34/62-A1.1	R-S-A1.1-(1.5)-...-67°	Working distance typ. 80 mm ... 200 mm
KL-M34/62-A2.0	R-S-A2.0-(2.5)-...-67°	Working distance typ. 80 mm ... 200 mm
KL-M34/62-A3.0	R-S-A3.0-(3.0)-...-67°	Working distance typ. 80 mm ... 200 mm
KL-M34/62-R1.1	R-S-R1.1-(3x0.5)-...-67°	Working distance typ. 80 mm ... 200 mm
KL-M34/62-R2.1	R-S-R2.1-(6x1)-...-67°	Working distance typ. 80 mm ... 200 mm

\*Special version:

Version is different to the standard version (e.g. no standard fiber adapter) and therefore is suitable only for certain sensors or applications





## Fiber Optics Fixtures

Mounting brackets (fixtures) for transmitted light fiber optics with sensor head type „A2.0“, „A3.0“, or „R2.1“:

Part number:	Suitable for fiber optics type: (D= transmitted light)	Characteristics:
KL-0/90°-22-A2.0	D-S-A2.0-(2.5)-...-67°	Transmitter/receiver distance 22 mm, fork width/depth: 50/50 mm
KL-0/90°-60-A2.0	D-S-A2.0-(2.5)-...-67°	Transmitter/receiver distance 22 mm, fork width/depth: 60/50 mm
KL-0/90°-100-A2.0	D-S-A2.0-(2.5)-...-67°	Transmitter/receiver distance 100 mm, fork width/depth: 100/50 mm
KL-0/90°-16-A3.0	D-S-A3.0-(3.0)-...-67°	Transmitter/receiver distance 16 mm, fork width/depth: 50/50 mm
KL-0/90°-60-A3.0	D-S-A3.0-(3.0)-...-67°	Transmitter/receiver distance 60 mm, fork width/depth: 94/50 mm
KL-0/90°-100-A3.0	D-S-A3.0-(3.0)-...-67°	Transmitter/receiver distance 100 mm, fork width/depth: 100/50 mm
KL-5/85°-A2.0	D-S-A2.0-(2.5)-...-67°	Angle of incidence 85° to the vertical in a distance of 5 mm to the object, gloss control of extremely rough surfaces
KL-5/85°-A3.0	D-S-A3.0-(3.0)-...-67°	Angle of incidence 85° to the vertical in a distance of 5 mm to the object, gloss control of extremely rough surfaces
KL-10/75°-A2.0	D-S-A2.0-(2.5)-...-67°	Angle of incidence 75° to the vertical in a distance of 10 mm to the object, gloss control of rough surfaces
KL-10/75°-A3.0	D-S-A3.0-(3.0)-...-67°	Angle of incidence 75° to the vertical in a distance of 10 mm to the object, gloss control of rough surfaces
KL-12/60°-A2.0	D-S-A2.0-(2.5)-...-67°	Angle of incidence 60° to the vertical in a distance of 12 mm to the object, gloss control of matt to light glossy surfaces
KL-12/60°-A3.0	D-S-A3.0-(3.0)-...-67°	Angle of incidence 60° to the vertical in a distance of 12 mm to the object, gloss control of matt to light glossy surfaces
KL-12/60°-R2.1	D-S-R2.1-(6x1)-...-67°	Angle of incidence 60° to the vertical in a distance of 12 mm to the object, gloss control of matt to light glossy surfaces
KL-15/45°-A2.0	D-S-A2.0-(2.5)-...-67°	Angle of incidence 45° to the vertical in a distance of 15 mm to the object, gloss control of matt to glossy surfaces
KL-15/45°-A3.0	D-S-A3.0-(3.0)-...-67°	Angle of incidence 45° to the vertical in a distance of 15 mm to the object, gloss control of matt to glossy surfaces
KL-20/20°-A2.0	D-S-A2.0-(2.5)-...-67°	Angle of incidence 20° to the vertical in a distance of 20 mm to the object, gloss control of very glossy surfaces
KL-20/20°-A3.0	D-S-A3.0-(3.0)-...-67°	Angle of incidence 20° to the vertical in a distance of 20 mm to the object, gloss control of very glossy surfaces

KL-0/90°-...-A2.0  
+ D-S-A2.0-(2.5)-...-67°



KL-0/90°-...-A3.0  
+ D-S-A3.0-(3.0)-...-67°

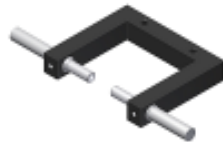

KL-5/85°-A2.0  
+ D-S-A2.0-(2.5)-...-67°

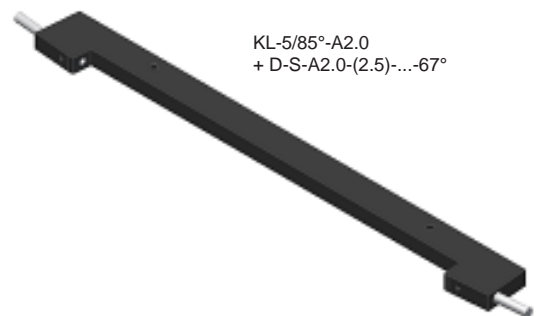

KL-10/75°-A2.0  
+ D-S-A2.0-(2.5)-...-67°



KL-12/60°-A2.0  
+ D-S-A2.0-(2.5)-...-67°



KL-15/45°-A2.0  
+ D-S-A2.0-(2.5)-...-67°

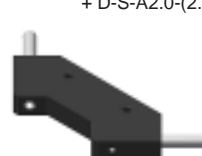

KL-20/20°-A2.0  
+ D-S-A2.0-(2.5)-...-67°





## Fiber Optics Fixtures

Mounting brackets (fixtures) for transmitted light fiber optics with sensor head type „Q....“ (cross-section converter):

Part number:	Suitable for fiber optics type: (D= transmitted light)	Characteristics:
KL-50/50-5	D-S-Q1-(5x0.5)-...-67°	Width of measuring range: 5 mm, transmitter/receiver distance: 50 mm, distance beginning of measurement range (inner side) to inner edge of housing: 50 mm
KL-50/50-10	D-S-Q2-(10x0.3)-...-67°	Width of measuring range: 10 mm, transmitter/receiver distance: 50 mm, distance beginning of measurement range (inner side) to inner edge of housing: 50 mm
KL-50/50-18	D-S-Q3-(18x0.3)-...-67°	Width of measuring range: 18 mm, transmitter/receiver distance: 50 mm, distance beginning of measurement range (inner side) to inner edge of housing: 50 mm
KL-50/50-28	D-S-Q4-(28x0.2)-...-67°	Width of measuring range: 28 mm, transmitter/receiver distance: 50 mm, distance beginning of measurement range (inner side) to inner edge of housing: 50 mm
KL-50/50-38	D-S-Q5-(38x0.15)-...-67°	Width of measuring range: 38 mm, transmitter/receiver distance: 50 mm, distance beginning of measurement range (inner side) to inner edge of housing: 50 mm
KL-50/50-48	D-S-Q6-(48x0.15)-...-67°	Width of measuring range: 48 mm, transmitter/receiver distance: 50 mm, distance beginning of measurement range (inner side) to inner edge of housing: 50 mm



KL-50/50-5  
+ D-S-Q1-(5x0.5)-...-67°

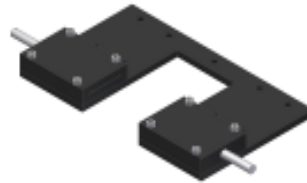

KL-50/50-28  
+ D-S-Q4-(28x0.2)-...-67°

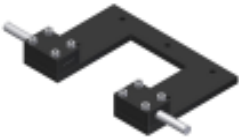

KL-50/50-10  
+ D-S-Q2-(10x0.3)-...-67°



KL-50/50-38  
+ D-S-Q5-(38x0.15)-...-67°

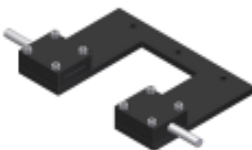

KL-50/50-18  
+ D-S-Q3-(18x0.3)-...-67°

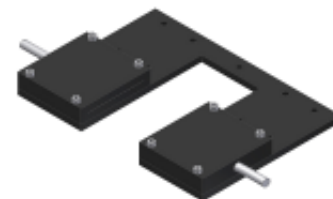

KL-50/50-48  
+ D-S-Q6-(48x0.15)-...-67°