

L-LAS Series

► L-LAS-LT-180-SL-...

- **Type -P:** Line laser, **Laser class 1** (<0.39 mW, wavelength 670 nm), visible red laser spot, typ. \varnothing 0.3 mm
- **Type -L:** Line laser, **Laser class 2** (<1 mW, wavelength 670 nm), visible red laser line, typ. 0.3 mm x 3 mm
- Reference distance 180 mm
- Measuring range typ. 240 mm:
Start of measuring range at typ. 60 mm
End of measuring range at typ. 300 mm
- Resolution typ. 60 μ m, reproducibility typ. \pm 60 μ m
- Interference filter and red light filter integrated
- CMOS line detector with 512 pixel, 4096 subpixel
- RS232 interface (USB or Ethernet converter available)
- Windows® user interface
- 2 digital inputs, 2 digital outputs
- 2 analog outputs (voltage 0...+10V and current 4...20mA)
- Scan frequency max. 2 kHz (3.3 kHz)
- Switching state indication via 2 three-color LEDs (red/grn/blu)
- Optics cover made of scratch-resistant glass



Design

Product name:

L-LAS-LT-180-SL-P

L-LAS-LT-180-SL-L

(incl. Windows® software L-LAS-LT-Scope as of V5.1)

P = Laser spot (typ. \varnothing 0.3 mm)
L = Laser line (typ. 0.3 mm x 3 mm)

8-pole connector
Binder Series 713/763
(connection to PLC)

Connecting cable:
cab-M12/8-g-...-shd or
cab-M12/8-w-...-shd or
cab-M12/8-g-...-shd-flx

Winkelstecker um 180°
drehbar

4-pole fem. conn.
Binder Series 707
(RS232 interface)

Connecting cable:
cab-las4/PC or
cab-4/USB or
cab-4/ETH

TEACH/RESET
button for norm
value teaching
or for reset of
maximum values

LED red/green/blue for
power indication
(green = Power)

LED red/green/blue for
tolerance band monitoring

Mounting holes

Transmitter
optics

Receiver
optics

Sturdy aluminium
housing, anodized
in black





Technical Data

Model	L-LAS-LT-180-SL-P	L-LAS-LT-180-SL-L
Light source	Semiconductor laser, 670 nm, DC-operation, 0.39 mW max. opt. power, laser class 1 acc. to DIN EN 60825-1. The use of these laser sensors therefore requires no additional protective measures.	Semiconductor laser, 670 nm, DC-operation, 1 mW max. opt. power, laser class 2 acc. to DIN EN 60825-1. The use of these laser sensors therefore requires no additional protective measures.
Reference distance	180 mm	
Measuring range	typ. 240 mm	
Start of measuring range	typ. 60 mm (measured from housing edge, cf. picture beam path)	
End of measuring range	typ. 300 mm (measured from housing edge, cf. picture beam path)	
Resolution	typ. 60 µm	
Reproducibility	typ. ± 60 µm	
Linearity	<= typ. 0.25% of full scale output (FSO)	
Laser line geometry	typ. Ø 0.3 mm	typ. 0.3 mm x 3 mm
Optical filter	Interference filter, red light filter RG630	
Analog outputs (I-OUT-ANA)	1x current output: I-OUT (4 ... 20mA) 1x voltage output: ANA (0 ... +10V)	
Digital outputs (OUT0, OUT1)	OUT0: (-) Measuring value < lower tolerance threshold OUT1: (+) Measuring value > upper tolerance threshold pnp bright-switching/npn dark-switching or pnp dark-switching/npn bright-switching, adjustable under Windows®, 100 mA, short-circuit proof	
Digital inputs (IN0, IN1)	IN0: External trigger, IN1: Teach/Reset (double function), input voltage +Ub/0V, with protective circuit	
Voltage supply	+24VDC (± 10%)	
Sensitivity setting	adjustable under Windows® via PC	
Laser power correction	adjustable under Windows® via PC	
Current consumption	typ. 200 mA	
Enclosure rating	Electronics: IP54, optics: IP67	
Temperature stability	typ. 0.01% of measuring range/°C	
Temperature ranges	operating temperature range: -10°C ... +50°C storage temperature range: -20°C ... +85°C	
Housing material	Aluminum, anodized in black	
Housing dimensions	LxWxH approx. 65 mm x 55 mm x 20.6 mm (without connectors)	
Type of connector	8-pole circular connector type Binder 713/763 (PLC/Power) 4-pole circular fem. connector type Binder 707 (PC/RS232)	
Connecting cable	to PLC: cab-M12/8-g-...-shd or cab-M12/8-w-...-shd or cab-M12/8-g-...-shd-flx to PC/RS232 interface: cab-las4/PC or cab-las4/PC-w to PC/USB interface: cab-4/USB or cab-4/USB-w to PC/Ethernet interface: cab-4/ETH	
LED indication (2x three-color LED)	1x three-color LED red/green/blue for tolerance band monitoring: red = Measuring value out of tolerance window green (ok) = Measuring value within tolerance window white = Measuring value out of measuring range 1x three-color LED red/green/blue for power indication: green = Power	
Teach/reset button	for norm value teaching or for reset of maximum values via input IN1	
EMC test acc. to	DIN EN 60947-5-2	
Measuring frequency	max. 2 kHz (3.3 kHz)	
Max. switching current	100 mA, short-circuit proof	
Interface	RS232, parameterisable under Windows®	
Output polarity	Bright/dark-switching, can be switched under Windows®	

Dimensions

L-LAS-LT-180-SL-P
L-LAS-LT-180-SL-L

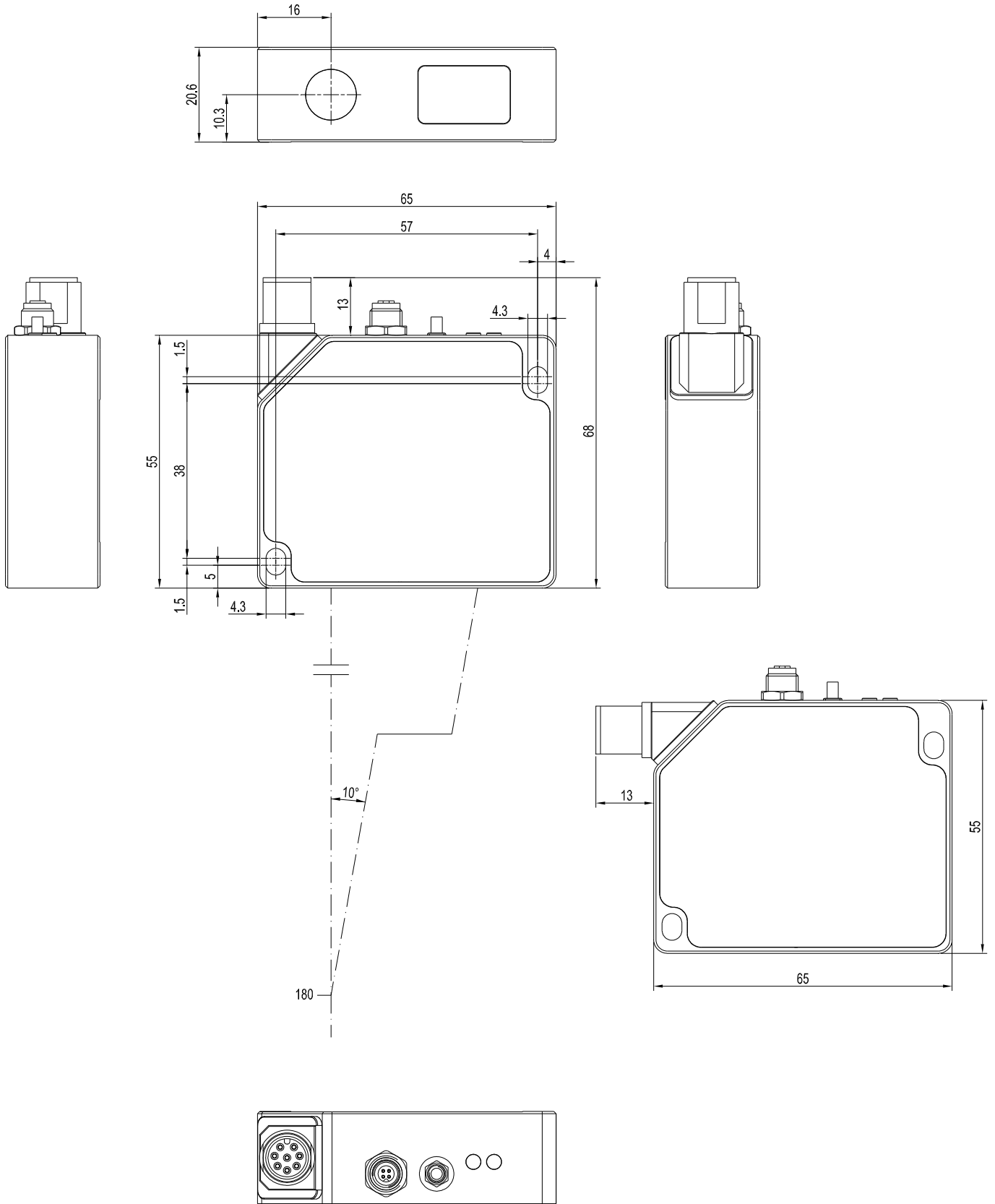

All dimensions in mm



Beam Path

L-LAS-LT-180-SL-P
L-LAS-LT-180-SL-L

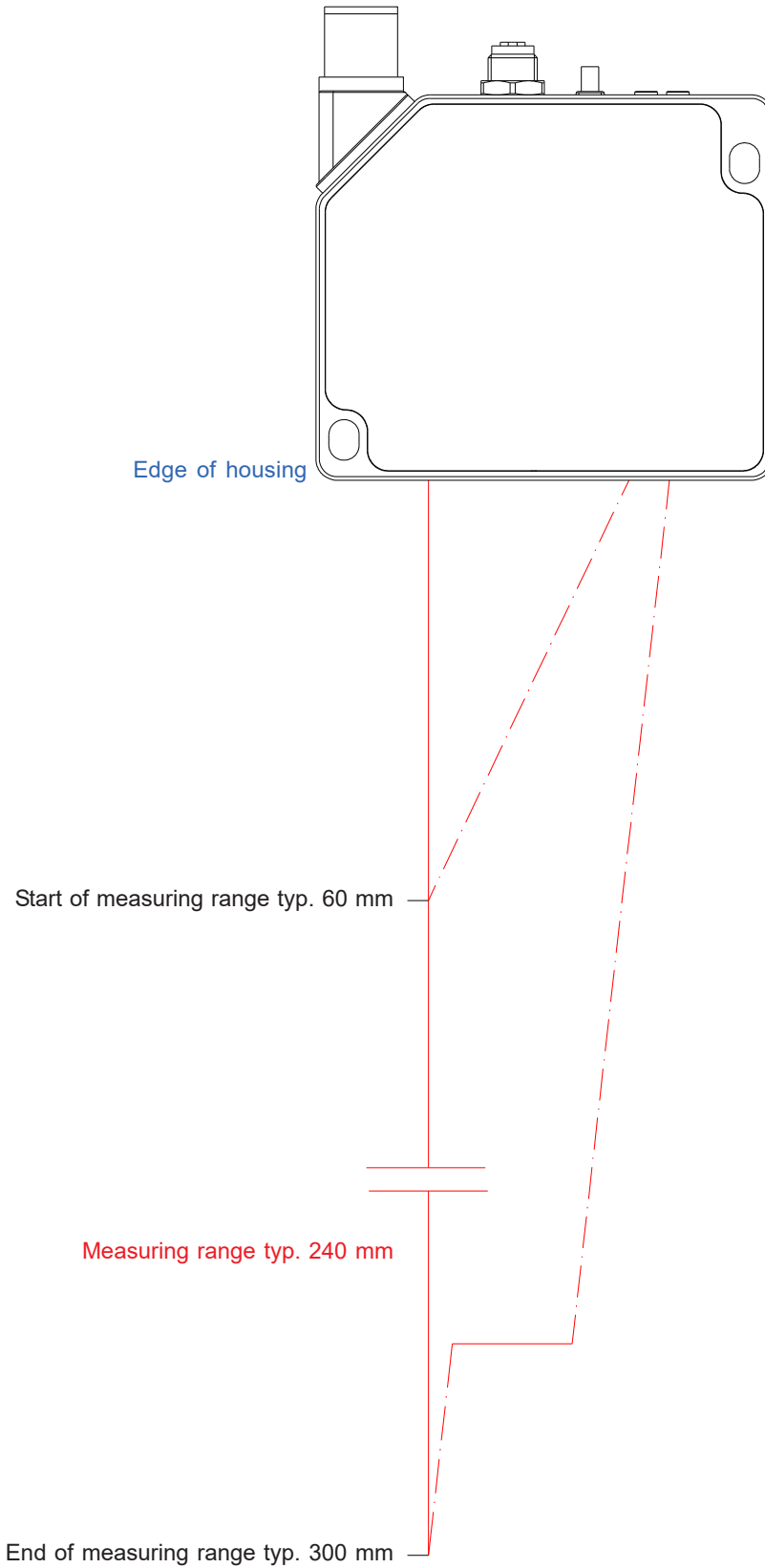



Connector Assignment

Connection to PLC:

8-pole M12 connector Binder Series 713/763

Pin:	Color:	Assignment:
1	white	OUT1
2	brown	+24VDC (± 10%)
3	green	ANA I-OUT (current 4...20mA)
4	yellow	IN1 (TEACH / RESET)
5	grey	OUT0
6	pink or black	ANA U-OUT (voltage 0...+10V)
7	blue	GND (0V)
8	red	IN0 (EXT TRIGGER)

Connecting cable:

cab-M12/8-g-(length)-shd (shielded)
 cab-M12/8-w-(length)-shd (shielded) (angle type 90°)
 (standard length 2m, also available: 5m)

optional:

cab-M12/8-g-(length)-shd-flx (shielded, suitable for drag chains)
 (standard length 2m, also available: 5m or 10m)

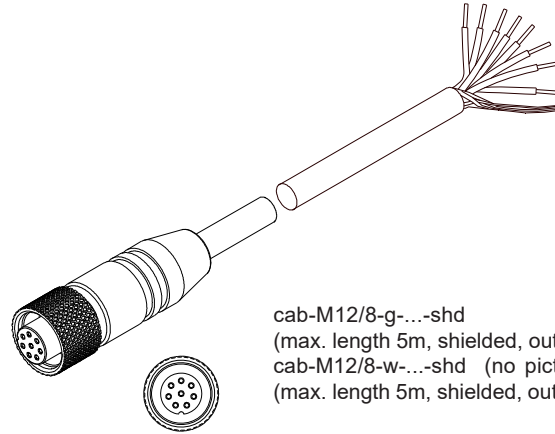

cab-M12/8-g-...-shd
 (max. length 5m, shd, shielded, outer jacket: PUR) or
 cab-M12/8-w-...-shd (no picture)
 (max. length 5m, shielded, outer jacket: PUR)

Connection to PC:

4-pole fem. connector Binder Series 707

Pin:	Assignment:
1	+24VDC (+Ub, OUT)
2	GND (0V)
3	RxD
4	TxD

Connection via RS232 interface at the PC:

Connecting cable:

cab-las4/PC-(length)
 cab-las4/PC-w-(length) (angle type 90°)
 (standard length 2m)

alternative:

Connection via USB interface at the PC:

USB converter (incl. driver software):

cab-4/USB-(length)
 cab-4/USB-w-(length) (angle type 90°)
 (standard length 2m)

alternative:

Connection to local network via Ethernet bus:

Ethernet converter (incl. software „SensorFinder“):

cab-4/ETH-500
 (standard length 0.5m)

Optional: External CAT5 cable, e.g.

cab-eth/M12D-RJ45-flx-(length)

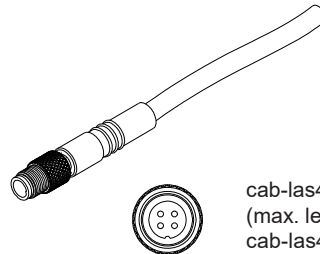
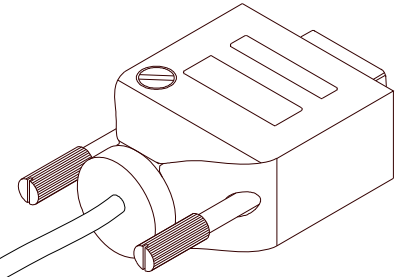

cab-las4/PC-...
 (max. length 10m, outer jacket: PUR) or
 cab-las4/PC-w-... (no picture)
 (max. length 5m, outer jacket: PUR)

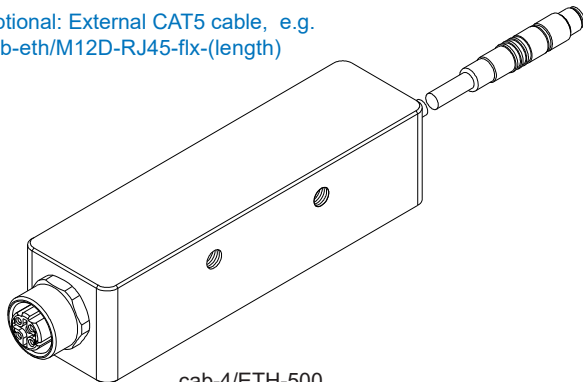
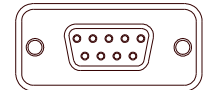

cab-4/ETH-500
 (length 0.5m, outer jacket: PUR)
 4-pole M12 fem. conn. (D-coded)
 for connection of an external
 CAT5 cable, e.g.
 cab-eth/M12D-RJ45-flx-(length)

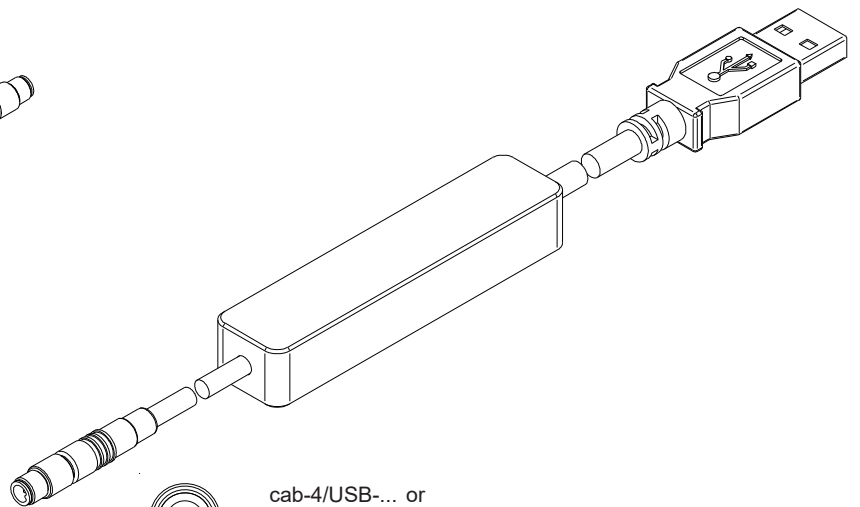

cab-4/USB-... or
 cab-4/USB-w-... (no picture)
 (each max. length 5m, outer jacket: PUR)





Angled Connector

Angled connector rotatable by 180°:

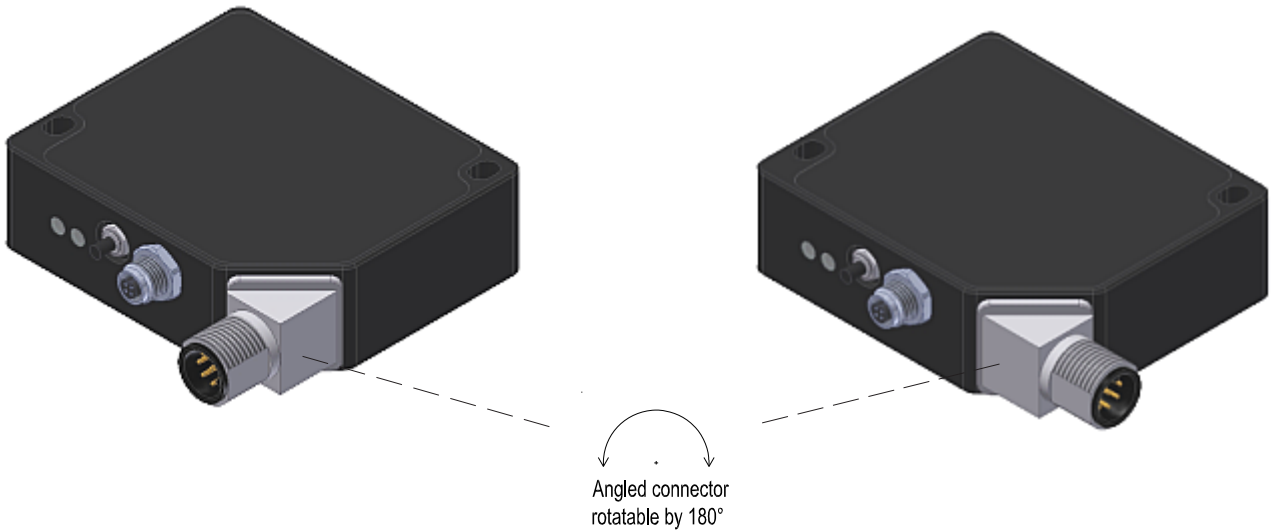

LED Display

LED display:

(power) ●●● (tolerance band monitoring)

LED red/grn/blu: ●
green = power

LED red/grn/blu: ●●○
red = measuring value out of tolerance window
green = measuring value within tolerance window
white = measuring value out of measuring range





Laser Warning

Laser class 1

is true for L-LAS-LT-180-SL-P:

The laser transmitters of L-LAS-LT-180-SL-P sensors comply with laser class 1 according to EN 60825-1. Under reasonably foreseeable conditions a class 1 laser is safe. The reasonably foreseeable conditions are kept during specified normal operation. The use of these laser transmitters therefore requires no additional protective measures.

The laser transmitters of L-LAS-LT-180-SL-P sensors are supplied with a laser information label „CLASS 1 Laser Product“.

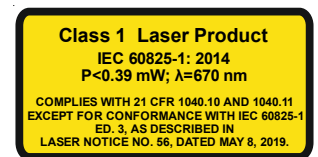

Laser class 2

is true for L-LAS-LT-180-SL-L:

The laser transmitters of L-LAS-LT-180-SL-L sensors comply with laser class 2 according to EN 60825-1. The use of these laser transmitters therefore requires no additional protective measures.

The laser transmitters of L-LAS-LT-180-SL-L sensors are supplied with a laser warning label „CLASS 2 Laser Product“.

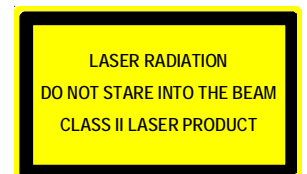



Parameterization
Windows® user interface:

(The current software version is available for download on our website.)

The L-LAS-LT-SL sensor can be easily parameterised with the Windows® user interface L-LAS-LT-Scope (as of V5.1). For this purpose the sensor is connected to the PC with the serial interface cable cab-las4/PC (or with USB cable cab-/USB or with Ethernet converter cab-4/ETH). When parameterisation is finished, the PC can be disconnected again.

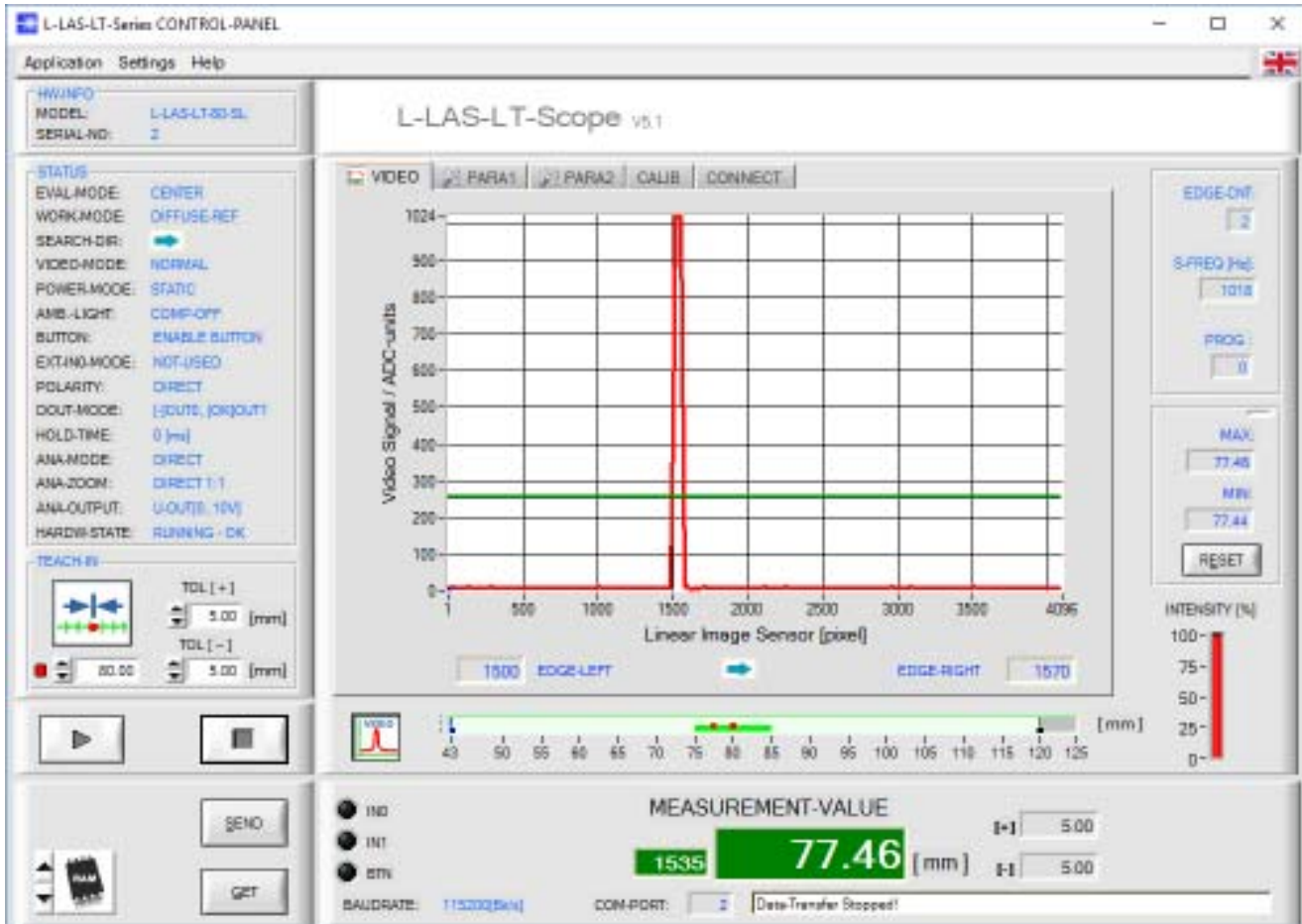

With the help of the L-LAS-LT-Scope software the following settings can be made at the sensor:

- Setting of laser power and type of automatic power correction
- Polarity of digital outputs
- Different evaluation modes
- Start of the teach process by software button
- Setting of tolerance ranges for monitoring the measured value
- Setting the exposure time: For particularly dark or matt surfaces, increasing the exposure time can help to ensure that sufficient intensity reaches the receiver line again
Increasing the exposure time reduces the scan frequency of the sensor (e.g. 0.5ms => 2000Hz, 5ms =>200Hz)
- Setting the video speed: Switch for specifying the readout speed on the line sensor receiver.
Increasing the readout speed reduces the resolution on the L-LAS-LT sensor:
NORMAL (normal readout frequency = full resolution) or FAST (fast readout frequency = half resolution)

Furthermore, various numerical and graphical measured quantities can be visualized with the L-LAS-LT-Scope software. For example, the raw data of the CCD line sensor can be displayed graphically and numerically.