

# SPECTRO Series

## ► SPECTRO-2-FIO-(IR2/IR)/(IR3/IR)

- Detection of the water content of various materials
- Transmitter channel 0: IR-LED (950nm) / Receiver channel 0: IR (900nm ... 1700nm)
- Transmitter channel 1: IR-LED (1450nm) / Receiver channel 1: IR (900nm ... 1700nm)
- Evaluation mode: Humidity measurement (HYGROMETRY)
- Fast evaluation methods in DC-operation available (up to 100kHz)
- Insensitive to outside light (in AC-operation)
- Parameterizable via Windows® software
- RS232 interface (RS232/Ethernet adapter and RS232/USB adapter available)
- Suitable for use in hazardous areas (fiber optics)
- Two analog outputs (0V... +10V and 4mA...20mA)
- Two digital outputs (0V/+24V)
- External trigger input and teach input
- Linearization by means of an editable linearization curve

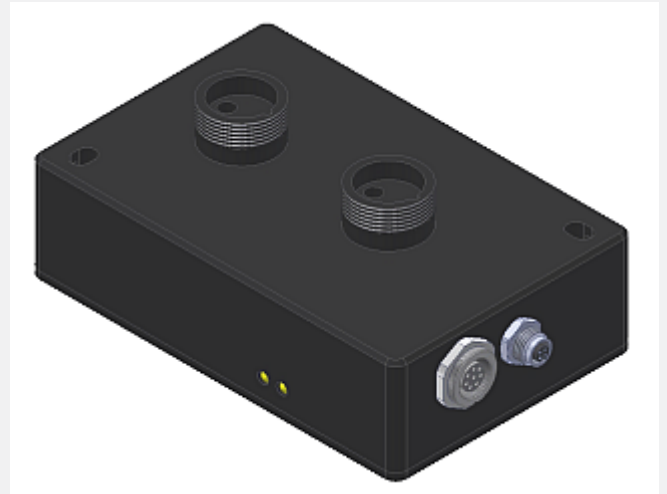

## Design

### Product name:

### SPECTRO-2-FIO-(IR2/IR)/(IR3/IR)\*

(incl. Windows® PC software SPECTRO2-Scope)

\*2-channel system

(Transmitter channel 0/Receiver channel 0)/

(Transmitter channel 1/Receiver channel 1)

**(IR2/IR)/(IR3/IR):**

Transm. channel 0: IR-LED (950nm) /

Receiver channel 0: IR (900nm ... 1700nm)

Transm. channel 1: IR-LED (1450nm) /

Receiver channel 1: IR (900nm ... 1700nm)

**Accessories:** (p. 8-11)

**Special fiber optics**

**Optical frontends**

**Fiber optics fixtures**

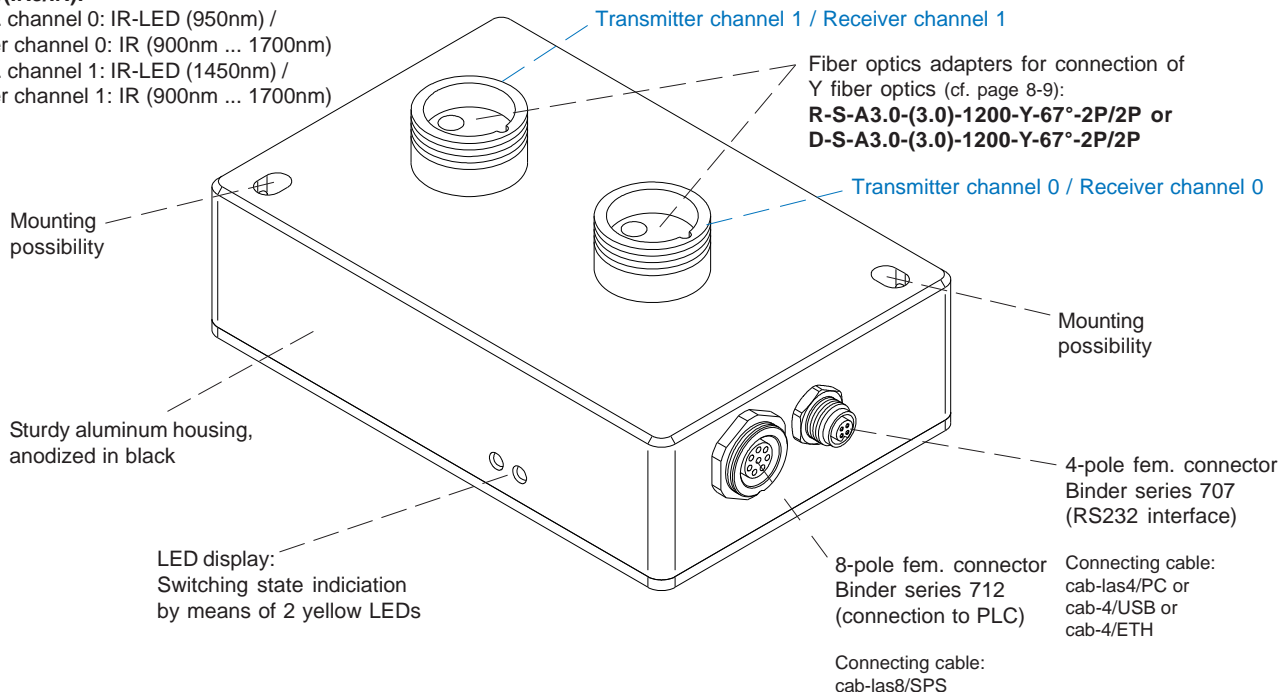

**Technical Data**

Model	SPECTRO-2-FIO-(IR2/IR)/(IR3/IR)
Voltage supply	+24VDC (± 10%), reverse polarity protected, overcurrent protected
Current consumption	< 160 mA
Max. switching current	100 mA, short circuit proof
Switching state indication	2 yellow LED visualize the physical state of the outputs OUT0 and OUT1
Inputs digital (2x)	IN0 and IN1 (Pin 3 and 4): digital (0V/+24V)
Outputs digital (2x)	OUT0 and OUT1 (Pin 5 and 6): digital (0V/+24V), npn/pnp-able (bright-/dark-switching, can be switched)
Outputs analog (1x)	ANALOG voltage 0 ... +10V or ANALOG current 4 ... 20mA (Pin 7)
Interface	RS232
Pulse lengthening	0 ... 100 ms, einstellbar über PC-Software
Averaging	max. 32768 values, adjustable via PC software
Scan frequency	LED operation, can be switched via PC software: AC operation: max. 85 kHz (depends on parameterization) DC and OFF operation: max. 200 kHz (depends on parameterization)
Switching frequency	typ. 60 kHz
Analog band width	typ. 90 kHz (-3 dB)
Transmitter (light source)	Transmitter channel 0: IR-LED (950 nm) Transmitter channel 1: IR-LED (1450 nm)
Receiver	Receiver channel 0: Photo diode with IR filter (900 nm ... 1700 nm) Receiver channel 1: Photo diode with IR filter (900 nm ... 1700 nm)
Transmitter control	can be switched via PC software: AC operation (LED MODE-AC), DC operation (LED MODE-DC), OFF operation (LED MODE-OFF)
Object distance (measurement range)	with reflected light fiber optics: typ. 1 mm ... 100 mm (depends on fiber optics and attachment optics) with transmitted light fiber optics: typ. 10 mm ... 200 mm (depends on fiber optics and attachment optics)
Receiver gain setting	8 steps (AMP1 ... AMP8), adjustable via PC software
Ambient light	max. 5000 Lux
Size of light spot	depends on fiber optics and attachment optics (cf. catalog FIO series)
Reproducibility	2 digits at 12-bit A/D conversion (equates 1/2048)
Housing dimensions	LxWxH approx. 100 mm x 65 mm x 38 mm (incl. fiber optics connector M18x1, without connectors)
Housing material	aluminum, anodized in black
Enclosure rating	IP64
Connecting cables	to PLC: cab-las8/SPS or cab-las8/SPS-w to PC/RS232 interface: cab-las4/PC or cab-las4/PC-w to PC/USB interface: cab-4/USB or cab-4/USB-w to PC/Ethernet interface: cab-4/ETH
Type of connector	connection to PLC: 8-pole fem. connector (Binder 712) connection to PC: 4-pole fem. connector (Binder 707)
Operating temp. range	-20°C ... +55°C
Storage temp. range	-20°C ... +85°C
EMC test acc. to	DIN EN 60947-5-2

Dimensions

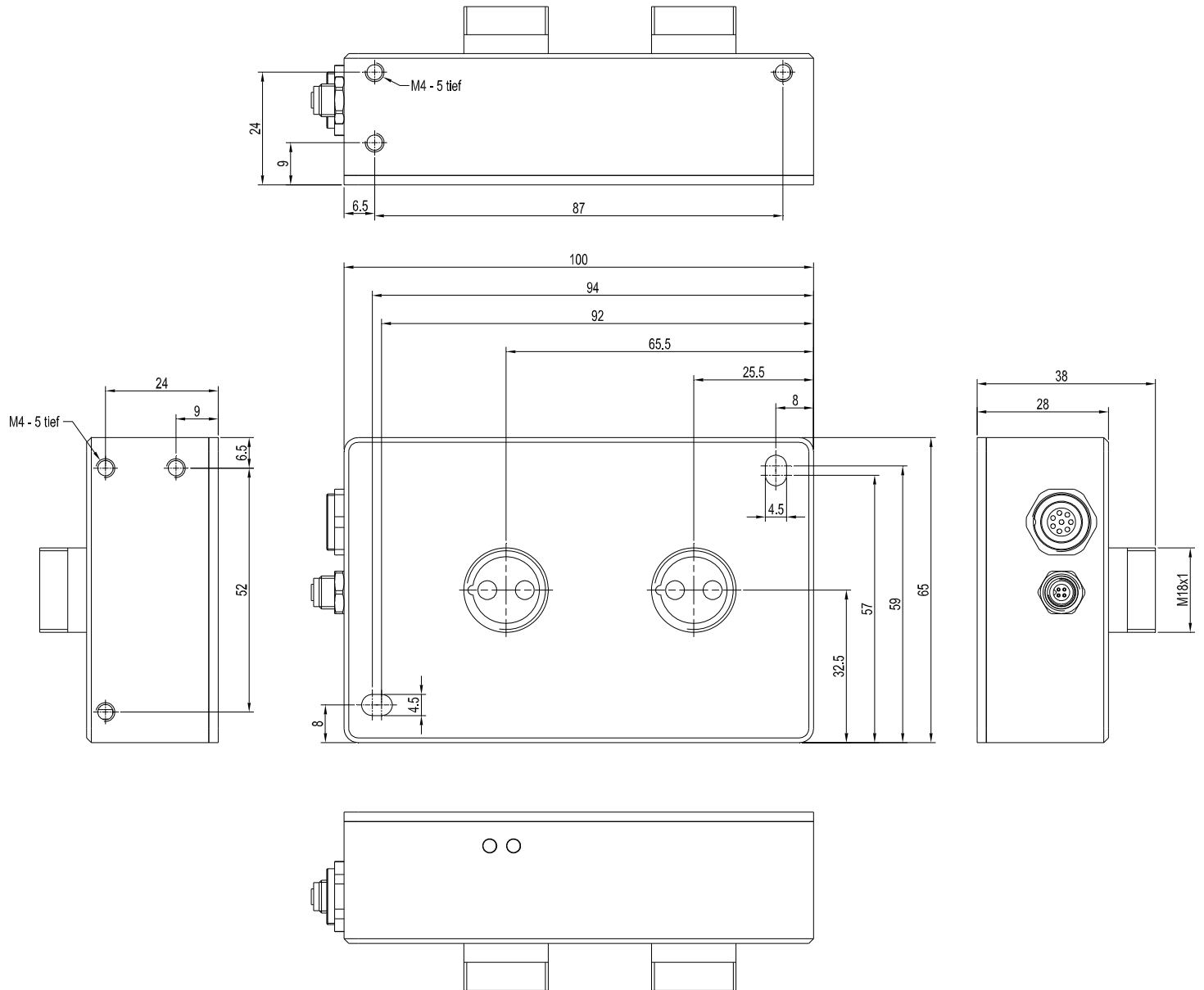

All dimensions in mm

## Connector Assignment

**Connection to PLC:****8-pole fem. connector Binder Series 712**

Pin:	Color:	Assignment:
1	white	GND (0V)
2	brown	+24VDC ( $\pm 10\%$ )
3	green	IN0 (Digital 0: 0 ... 1V, Digital 1: +Ub - 10%)
4	yellow	IN1 (Digital 0: 0 ... 1V, Digital 1: +Ub - 10%)
5	grey	OUT0 (Digital 0: Type 0 ... 1V, Digital 1: Type +Ub - 10%)
6	pink	OUT1 (Digital 0: Type 0 ... 1V, Digital 1: Type +Ub - 10%)
7	blue	ANALOG (0 ... +10V or 4 ... 20mA)
8	red	n.c.

**Connecting cable:**

cab-las8/SPS-(length)

cab-las8/SPS-w-(length) (angle type, 90°)

(standard length 2m)

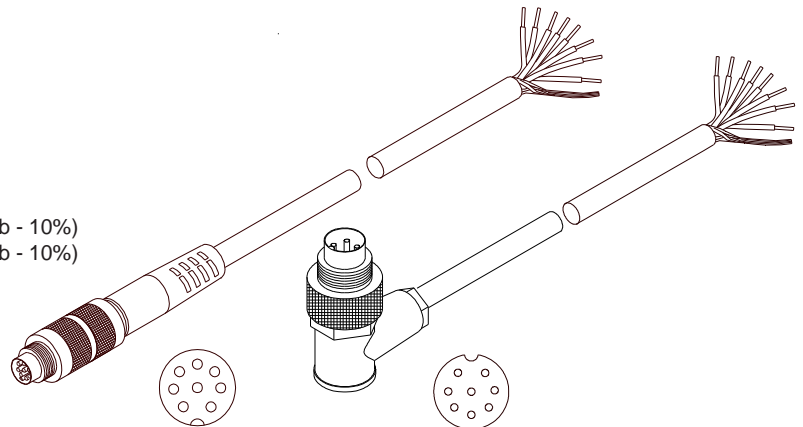
cab-las8/SPS-...  
(max. length 25m,  
outer jacket: PUR)cab-las8/SPS-w-...  
(max. length 25m,  
outer jacket: PUR)**Connection to PC:****4-pole fem. connector Binder Series 707**

Pin:	Assignment:
1	+24VDC (+Ub, OUT)
2	GND (0V)
3	RxD
4	TxD

**Connection via RS232 interface at the PC:****Connecting cable:**

cab-las4/PC-(length)

cab-las4/PC-w-(length) (angle type 90°)

(standard length 2m)

**alternative:****Connection via USB interface at the PC:****Connecting cable (incl. driver software):**

cab-4/USB-(length)

cab-4/USB-w-(length) (angle type 90°)

(standard length 2m)

**alternative:****Connection to local network via Ethernet bus:****Adapter (incl. software „SensorFinder“):**

cab-4/ETH-500

(standard length 0.5m)

**Optional: External CAT5 cable, e.g.**

cab-eth/M12D-RJ45-flx-(length)

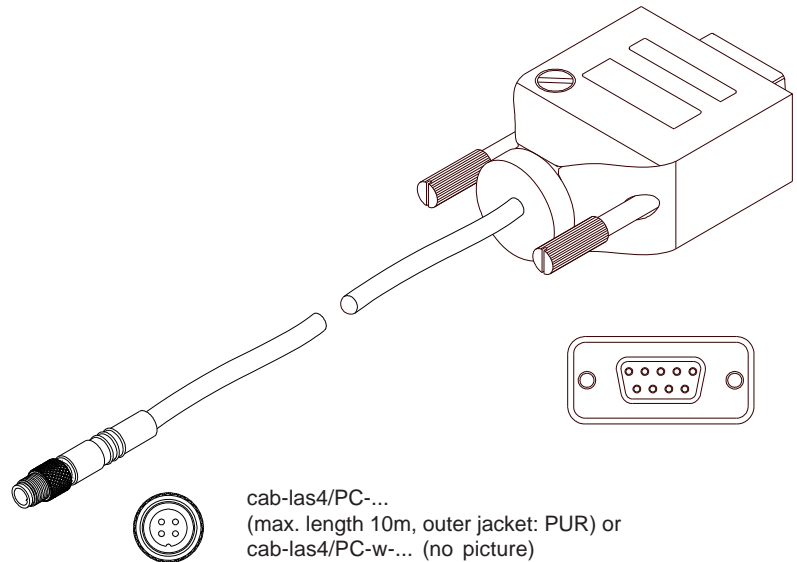
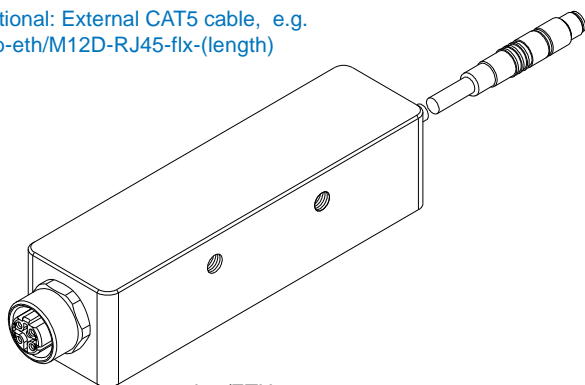
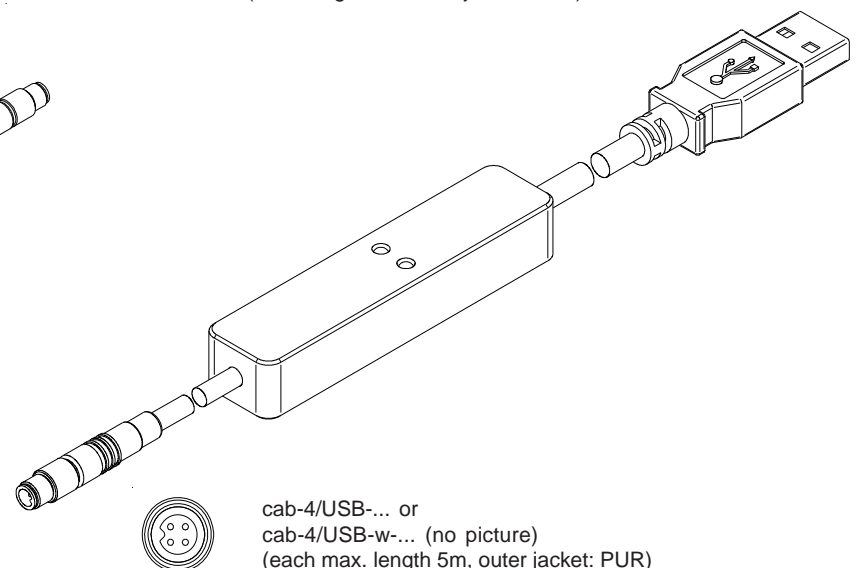
cab-las4/PC-...  
(max. length 10m, outer jacket: PUR) or  
cab-las4/PC-w-... (no picture)  
(max. length 5m, outer jacket: PUR)cab-4/ETH-500  
(length 0.5m, outer jacket: PUR)  
4-pole M12 fem. conn. (D-coded)  
for connection of an external  
CAT5 cable, e.g.  
cab-eth/M12D-RJ45-flx-(length)cab-4/USB-... or  
cab-4/USB-w-... (no picture)  
(each max. length 5m, outer jacket: PUR)



## LED Display

### LED display:

By means of the two LEDs the physical state of the two outputs OUT0 and OUT1 is visualized:

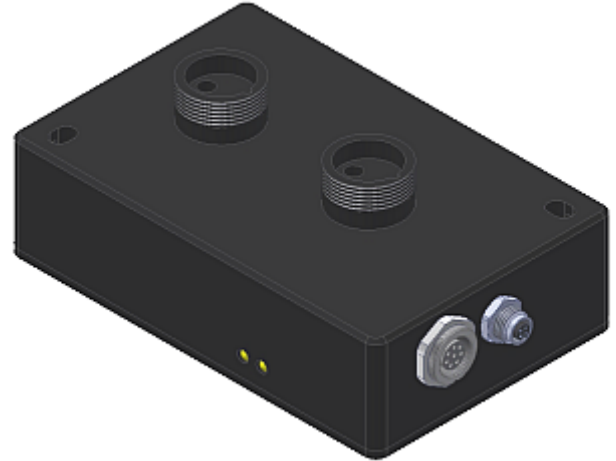
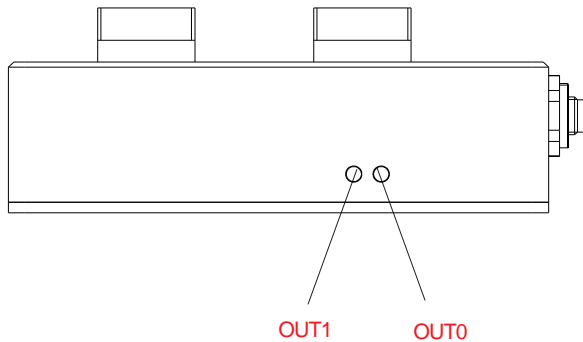

## Measuring Principle

### Measuring principle of the sensors of SPECTRO-2 series:

The SPECTRO-2-FIO sensor is a 2-channel system, which means it features two fiber optics connections that (initially) are independent of each other. All the fiber optics of the FIO series (through-beam fiber optics type D-... and reflective fiber optics type R-... as well as fiber optics with two sensor heads type X-...) can be used with this sensor.

The desired operating mode can be set with the SPECTRO2-Scope Windows® software:

- Separate evaluation (every channel operates independently, typ. 2-channel system)
- Normed evaluation (the relation of the two channels is determined by way of norming)
- Summation (the two channels are added)
- Subtraction (the difference of the two channels is calculated)
- Differentiation (calculation of the first derivative of the two channels)

To prevent mutual influencing of the two channels, different optical filters (depending on the respective type) or a timing offset of the respective LED can be used.



Parameterization

**Windows® user interface:**

(The current software version is available for download on our website.)

The PC software SPECTRO2-Scope facilitates the parameterization, the diagnosis, and the adjustment of the sensor system (oscilloscope function). Moreover, the software features a data recorder function that allows the automatic recording of recorded data and the saving of those at the hard disk of the PC.

Parameters and measurement values can be exchanged between PC and sensor either through RS232 or Ethernet (using an Ethernet adaptor). Through the interface all the parameters can be stored in the non-volatile EEPROM of the sensor.

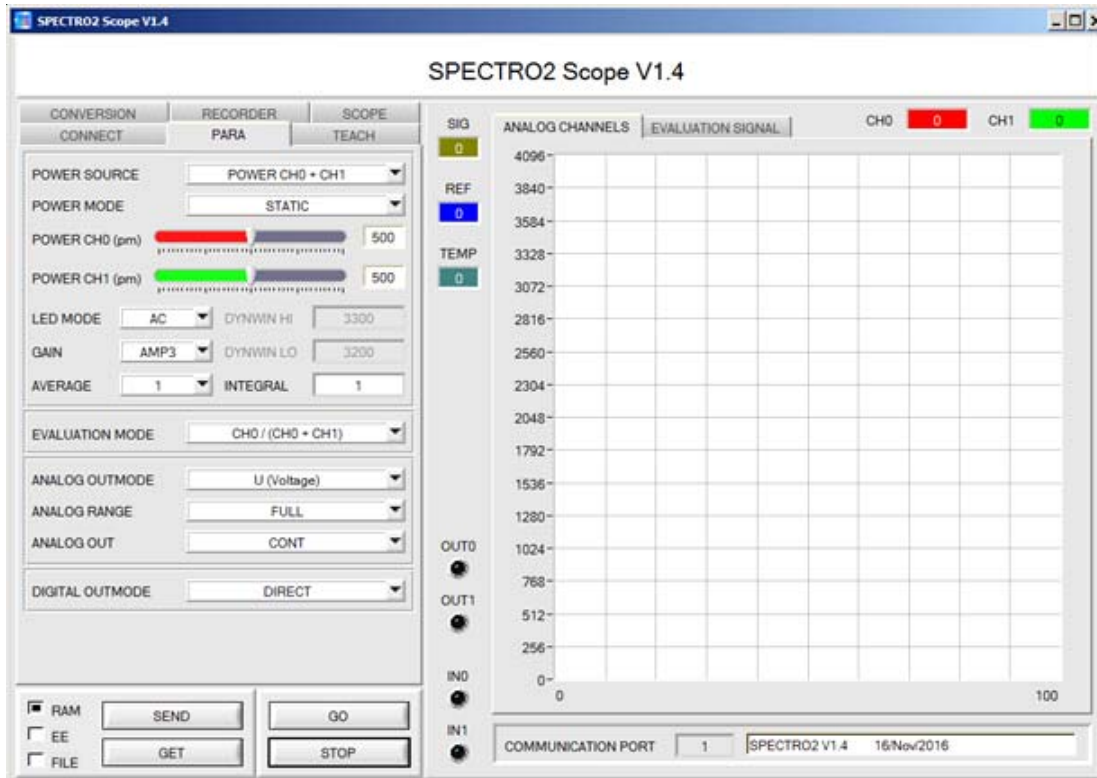

The SCOPE tab visualizes an oscilloscope.

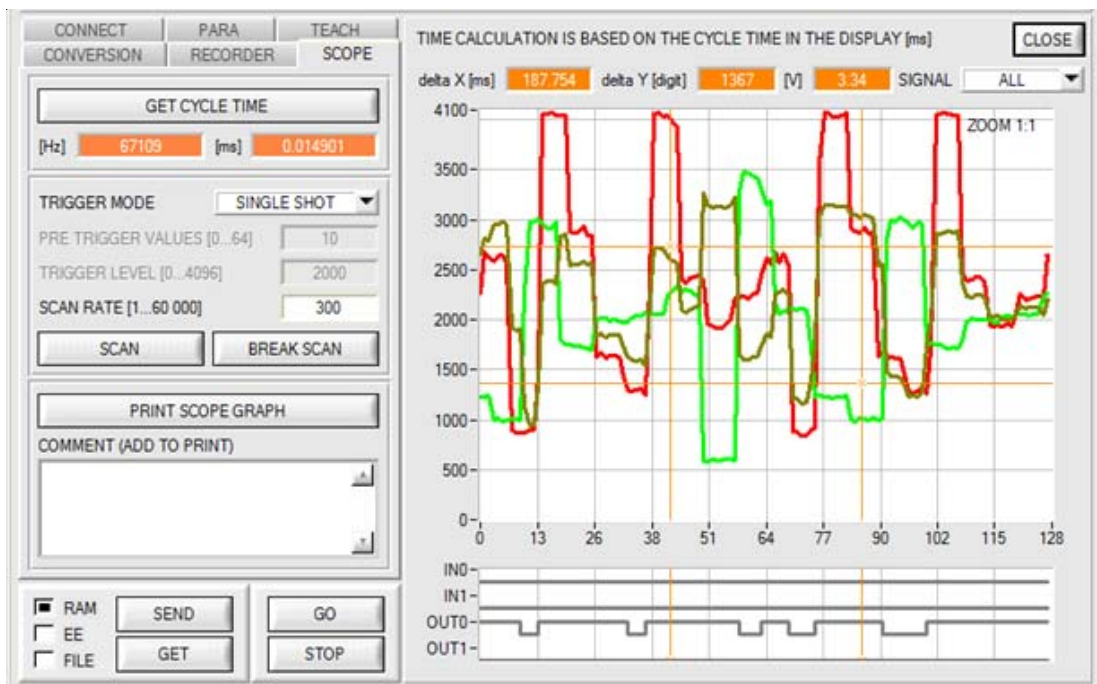



## Firmware Update

### Firmware update by means of the software „FirmwareLoader“:



The software „Firmware Loader“ allows the user to perform an automatic firmware update. The update will be carried out through the RS232 interface.

An initialisation file (xxx.ini) and a firmware file (xxx.elf.S) are required for performing a firmware update. These files can be obtained from your supplier. In some cases an additional firmware file for the program memory (xxx.elf.p.S) is also needed, and this file will be automatically provided together with the other two files.



Special Fiber Optics

R-S-A3.0-(3.0)-1200-Y-67°-2P/2P  
Reflected light fiber optics (Y-version)

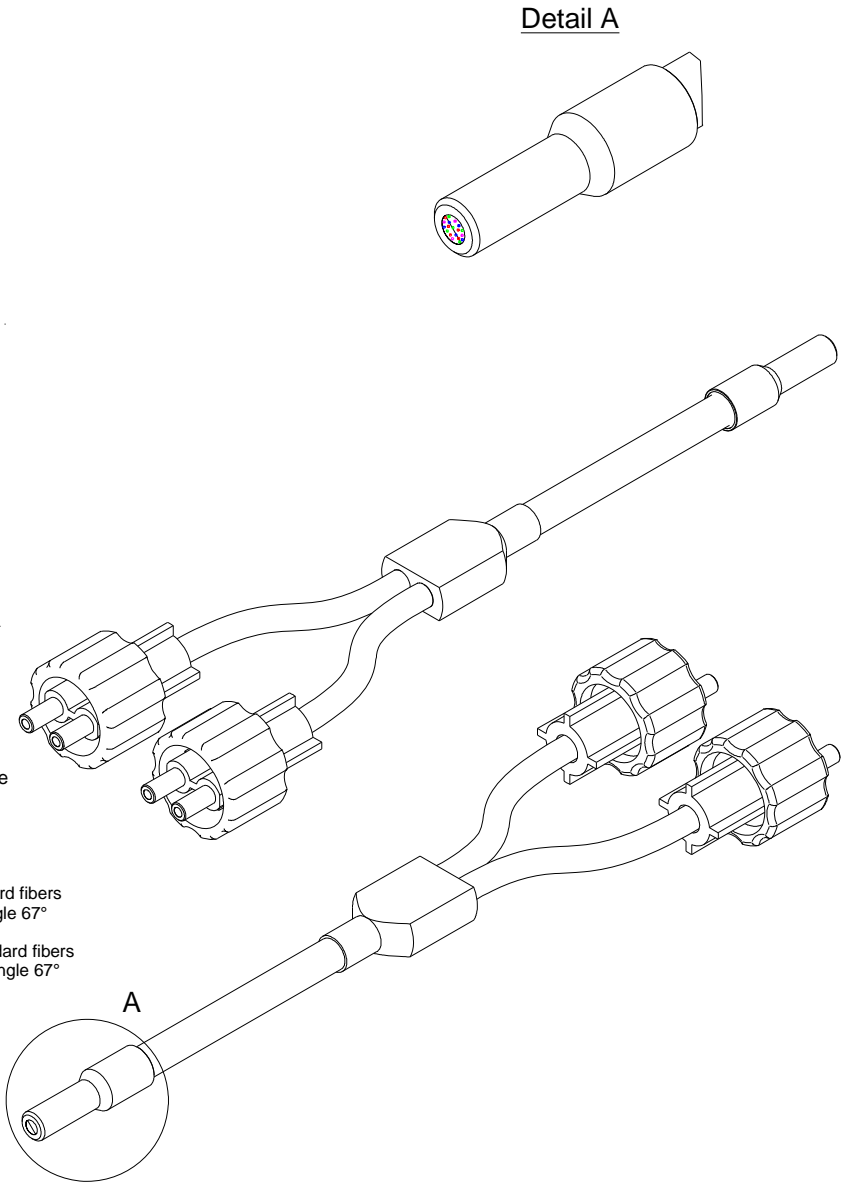
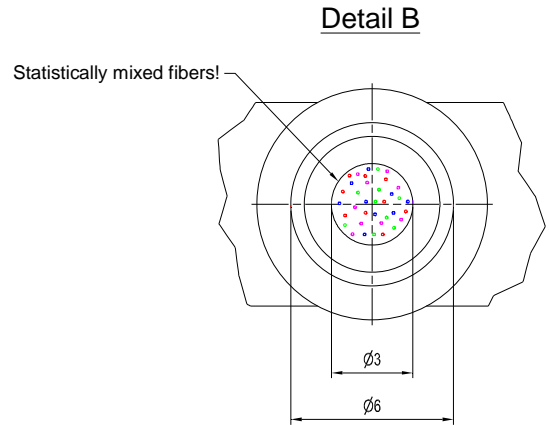
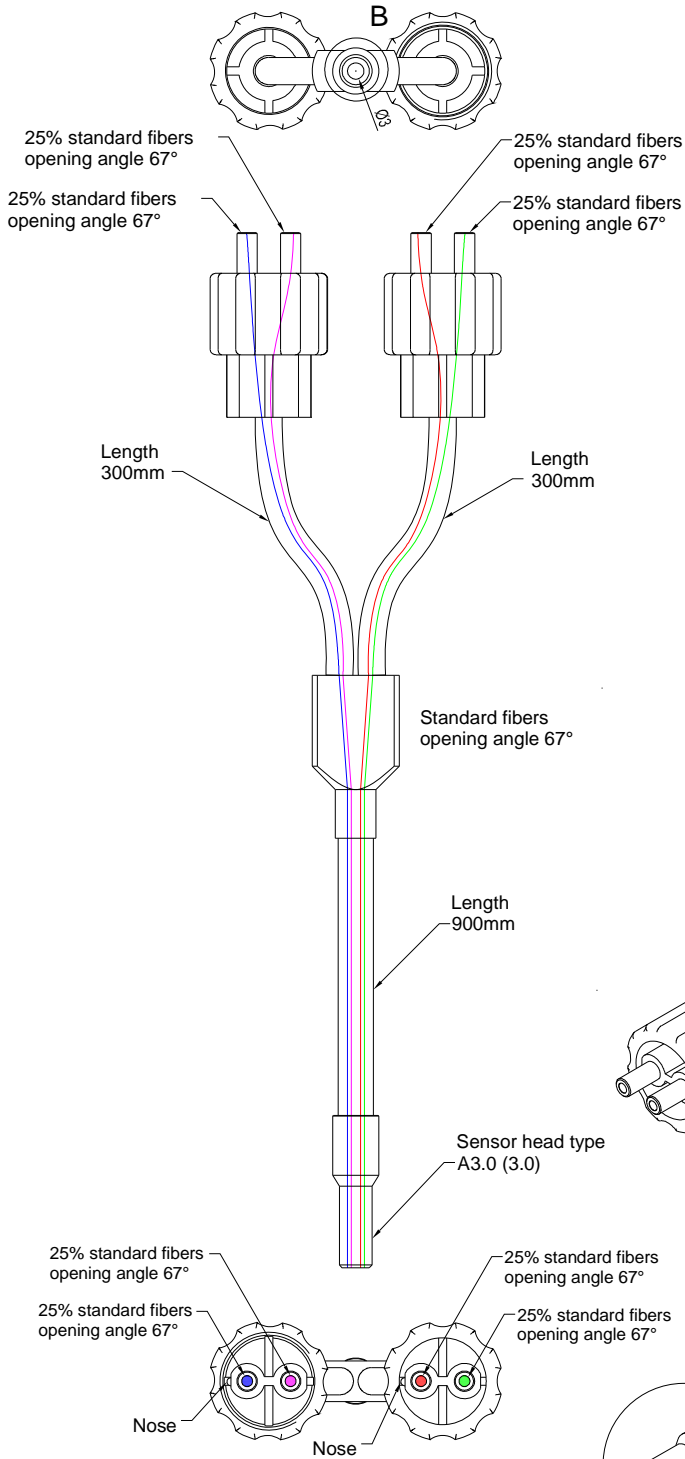

All dimensions in mm



Special Fiber Optics

D-S-A3.0-(3.0)-1200-Y-67°-2P/2P  
Transmitted-light fiber optics (Y-version)

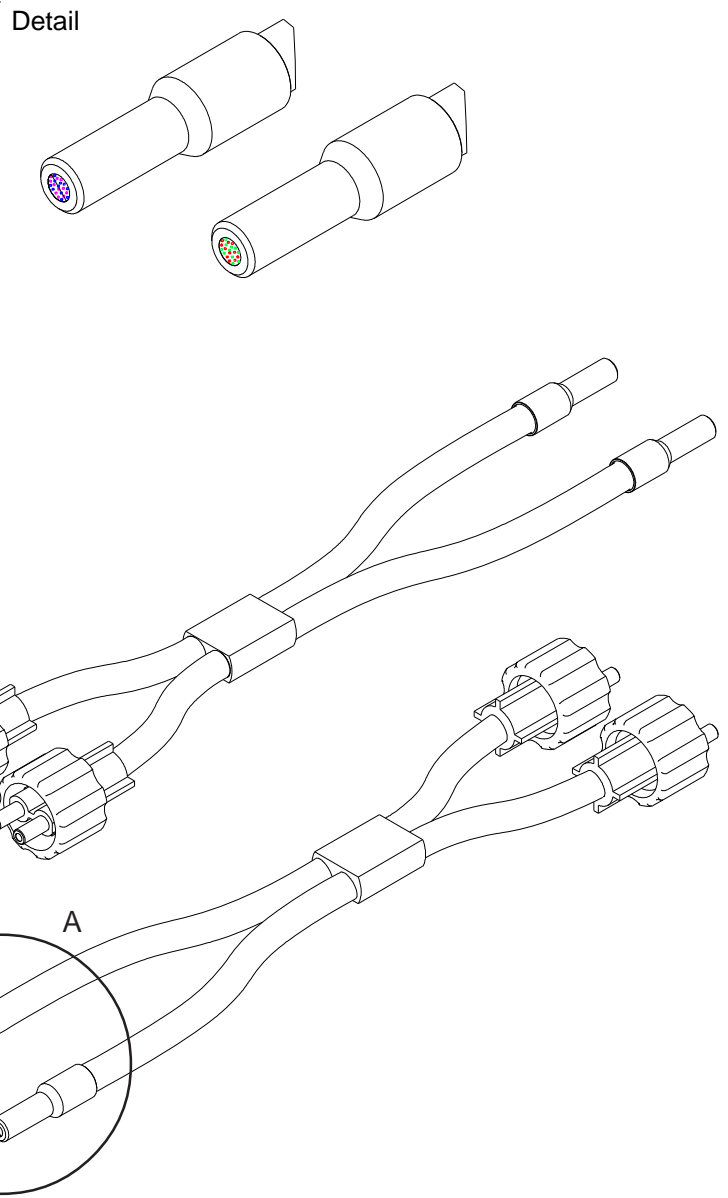
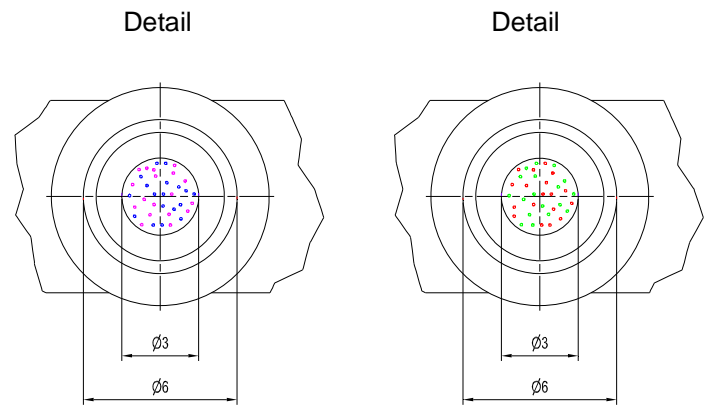
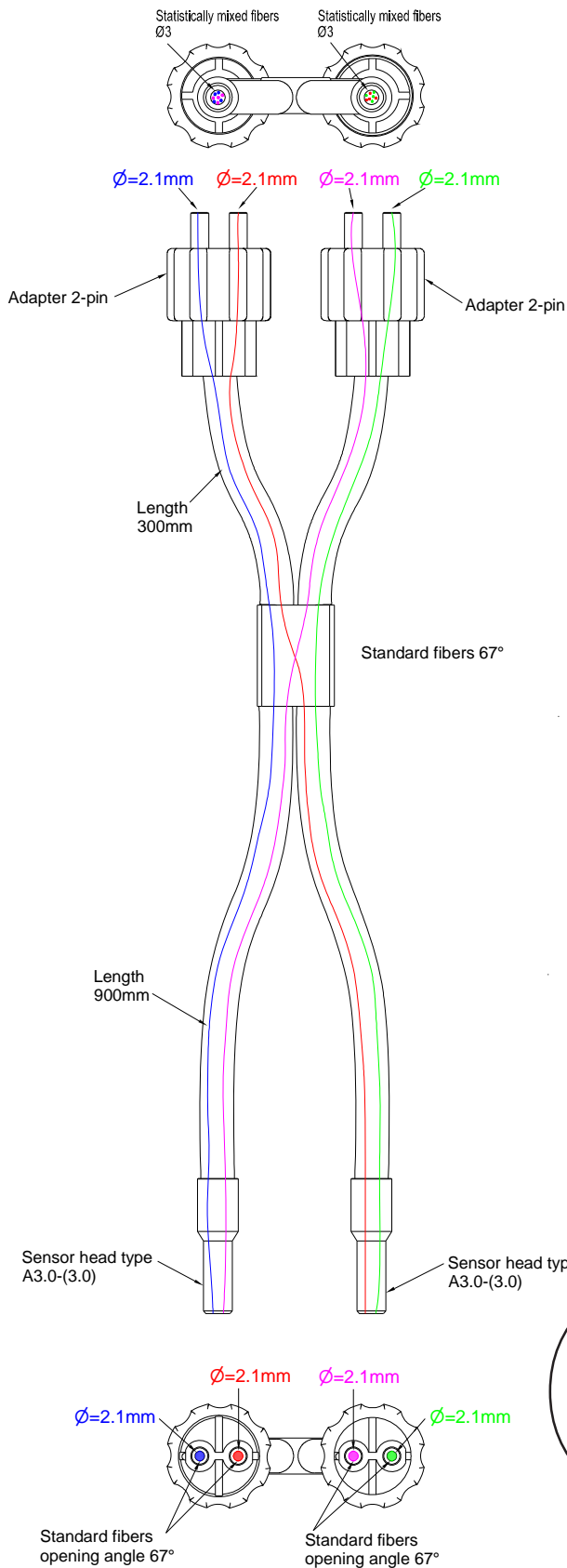

All dimensions in mm



Optical Frontends

Overview: Optical frontends for fiber optics with sensor head type „A3.0“:



KL-9-A3.0



KL-M12-A3.0



KL-M18-A3.0



KL-M18-XL-A3.0



KL-M34-A3.0



KL-M34-XL-A3.0



KL-M34/62-A3.0



KL-52-XL-A3.0

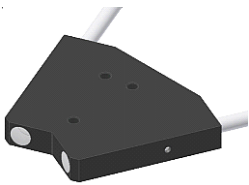

KL-D-0°/45°-30-A3.0



KL-D-5°-85-POL-A3.0



KL-D-10°-45-POL°-A3.0



KL-D-20°-20-POL-A3.0

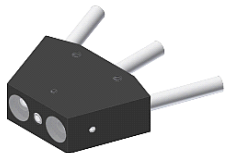

KL-D-40°-23-5/DIF-A3.0



KL-D-M12-0°/30°-9-A3.0

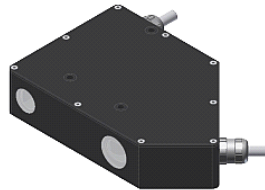

KL-D-0°/45°-85-1200-A3.0



Lichtleiter-Halterungen

Mounting brackets (fixtures) for transmitted light fiber optics with sensor head type „A3.0“:

Part number:	Suitable for fiber optics type: (D= transmitted light)	Characteristics:
C-MOUNT-A3.0-180°-16/50	D-S-A3.0-(3.0)-...-67°	Transmitter/receiver distance 16 mm, fork width/depth: 50/50 mm
C-MOUNT-A3.0-180°-60/50	D-S-A3.0-(3.0)-...-67°	Transmitter/receiver distance 60 mm, fork width/depth: 94/50 mm
C-MOUNT-A3.0-180°-100/50	D-S-A3.0-(3.0)-...-67°	Transmitter/receiver distance 100 mm, fork width/depth: 100/50 mm
MOUNT-A3.0-170°-5	D-S-A3.0-(3.0)-...-67°	Angle of incidence 85° to the vertical in a distance of 5 mm to the object, gloss control of extremely rough surfaces
MOUNT-A3.0-150°-10	D-S-A3.0-(3.0)-...-67°	Angle of incidence 75° to the vertical in a distance of 10 mm to the object, gloss control of rough surfaces
MOUNT-A3.0-120°-12	D-S-A3.0-(3.0)-...-67°	Angle of incidence 60° to the vertical in a distance of 12 mm to the object, gloss control of matt to light glossy surfaces
MOUNT-A3.0-90°-15	D-S-A3.0-(3.0)-...-67°	Angle of incidence 45° to the vertical in a distance of 15 mm to the object, gloss control of matt to glossy surfaces
MOUNT-A3.0-40°-20	D-S-A3.0-(3.0)-...-67°	Angle of incidence 20° to the vertical in a distance of 20 mm to the object, gloss control of very glossy surfaces

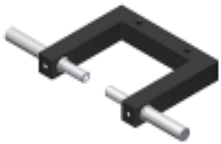

C-MOUNT-A3.0-180°-.../50  
+ D-S-A3.0-(3.0)-...-67°



MOUNT-A3.0-40°-20  
+ D-S-A3.0-(3.0)-...-67°



MOUNT-A3.0-90°-15  
+ D-S-A3.0-(3.0)-...-67°



MOUNT-A3.0-120°-12  
+ D-S-A3.0-(3.0)-...-67°



MOUNT-A3.0-150°-10  
+ D-S-A3.0-(3.0)-...-67°



MOUNT-A3.0-170°-5  
+ D-S-A3.0-(3.0)-...-67°