

# L-LAS Series

## ▶ L-LAS-GTM-256/16

- Visible laser spot (red), class 2 laser product
- Integrated interference filter / red light filter
- CCD line detector with 256 pixel
- External teach button and potentiometer for tolerance setting
- RS232 interface and Windows® user interface
- 1 digital input
- 2 digital outputs, 1 analog output (0...10V)
- Switching state indication via 3 LEDs (1x green, 2x red)
- Sturdy aluminum housing
- Optics cover made of scratch-resistant glass
- Detection of the position of a coated glass surface
- Glass thickness monitoring

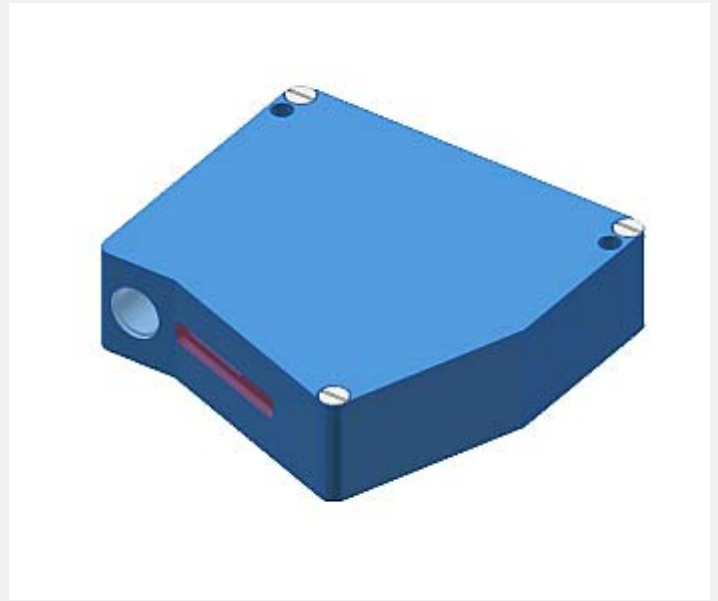

### Design

#### Product name:

#### **L-LAS-GTM-256/16**

(incl. Windows® software L-LAS-GTM-Scope)

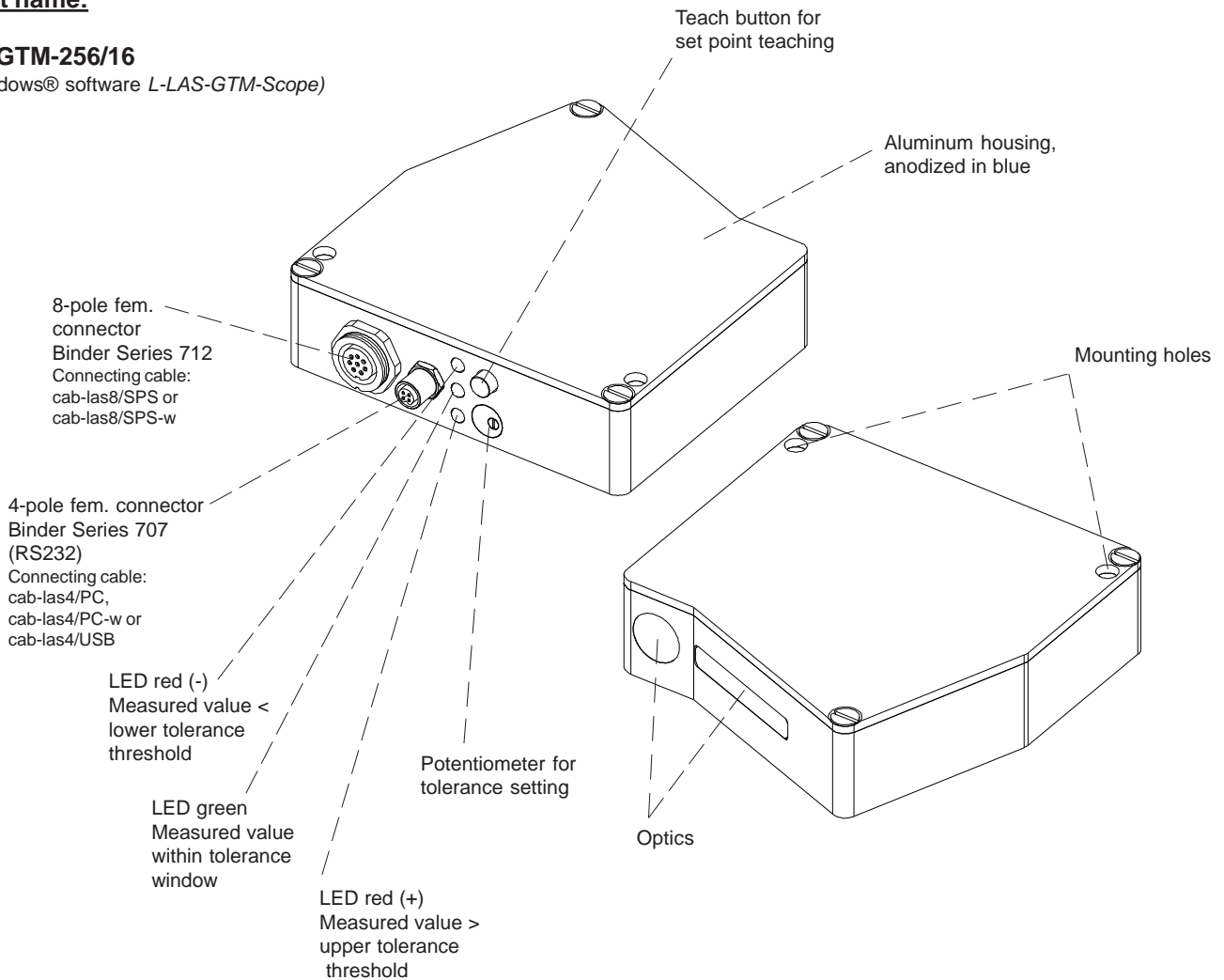



**Technical Data**

Model	L-LAS-GTM-256/16
Laser	Semi-conductor laser, 670 nm, DC-operation, 1 mW max. opt. power, laser class 2 acc. to DIN EN 60825. The use of these laser sensors therefore requires no additional protective measures.
Optical filter	Interference filter, red light filter RG630
Analog output	0 ... 10V
Digital outputs (OUT0, OUT1)	pnp bright-switching/npn dark-switching or pnp dark-switching/npn bright-switching, adjustable under Windows® on PC, 100 mA, short-circuit proof
Digital input (IN0)	Input voltage +Ub/0V, with protective circuit
Voltage supply	+12VDC ... +30VDC
Sensitivity setting	under Windows® on PC as well as via integrated potentiometer
Laser power correction	adjustable under Windows® on PC
Current consumption	typ. 200 mA
Enclosure rating	Electronics: IP64, Optics: IP67
Operating temperature range	0°C ... +50°C
Storage temperature range	-20°C ... +85°C
Housing material	Aluminum, anodised in blue
Housing dimensions	LxWxH ca. 80 mm x 65 (81,5) mm x 22 mm (without flange connectors)
Type of connector	8-pole female connector type Binder 712 (PLC/Power) 4-pole female connector type Binder 707 (PC/RS232)
Potentiometer	3 revolutions, for setting of tolerance thresholds
Teach button	for set point teaching
LED display	LED red (+) : Measuring value > upper toleranz threshold LED green : Voltage indication/visualisation of teach process LED red (-) : Measuring value < lower tolerance threshold
EMC test acc. to	DIN EN 60947-5-2
Measuring frequency	typ. 200 Hz (without averaging)
Max. switching current	100 mA, short-circuit proof
Serial interface	RS232, parameterisable under Windows®
Connecting cable	Connection to PC: cab-las4/PC or cab-las4/PC-w Connection to PLC: cab-las8/SPS or cab-las8/SPS-w
Output polarity	Bright/dark-switching, adjustable under Windows® on PC
Reference distance	10 mm ... 80 mm, depends on the sensor adjustment to the object (position of angle)
Measuring range	depends on the sensor adjustment to the object (position of angle)
Length of detector	typ. 16 mm



Dimensions

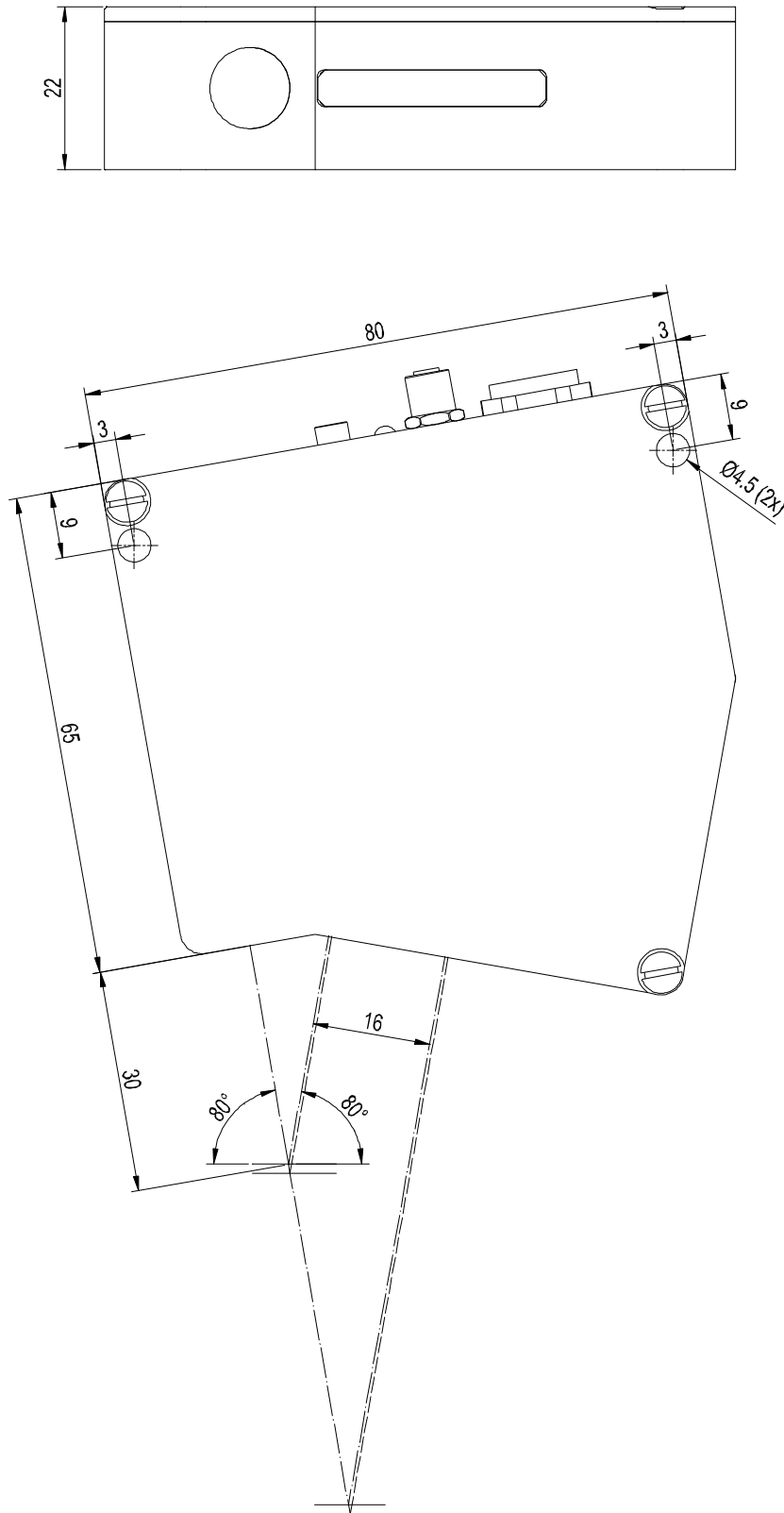

All dimensions in mm

**Connector Assignment**

**Connection to PLC:  
8-pol. Buchse Binder Serie 712**

Pin:	Color:	Assignment:
1	white	GND (0V)
2	brown	+24VDC (± 10%)
3	green	IN0
4	yellow	IN1 (n.c.)
5	grey	OUT0
6	pink	OUT1
7	blue	GND (0V)
8	red	ANA (0 ... +10V)

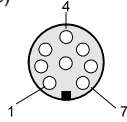

Connecting cable to PLC:  
**cab-las8/SPS**

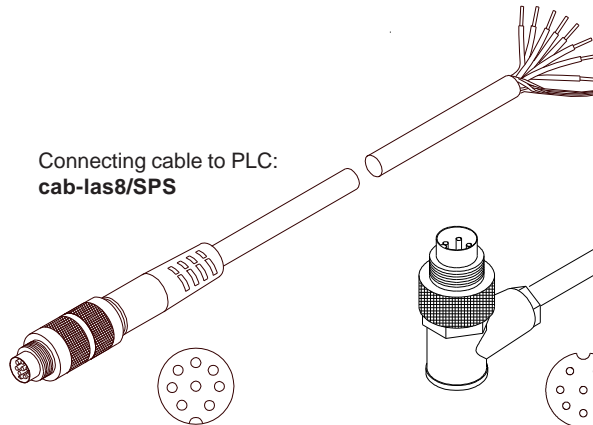

Connecting cable to PLC:  
**cab-las8/SPS-w**

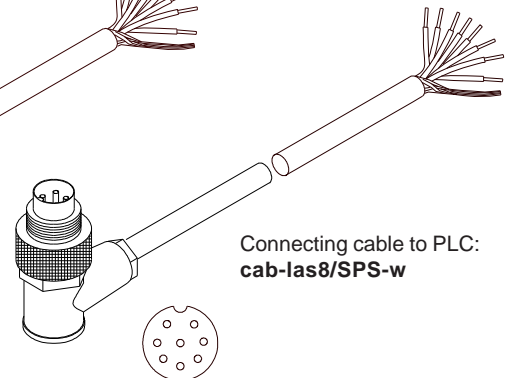

Connecting cable:  
cab-las8/SPS-(length)  
cab-las8/SPS-w-(length) (angle type, 90°)  
(Standard length 2m)

**Connection to PC:  
4-pole fem. connector Binder Series 707**

Pin:	Assignment:
1	+24VDC (+Ub, OUT)
2	GND (0V)
3	RxD
4	TxD

Connecting cable:  
cab-las4/PC-(length)  
cab-las4/PC-w-(length) (angle type, 90°)  
(Standard length 2m)

alternatively:  
Connecting cable (incl. driver software):  
cab-las4/USB-(length)  
cab-las4/USB-w-(length) (angle type 90°)  
(Standard length 2m)

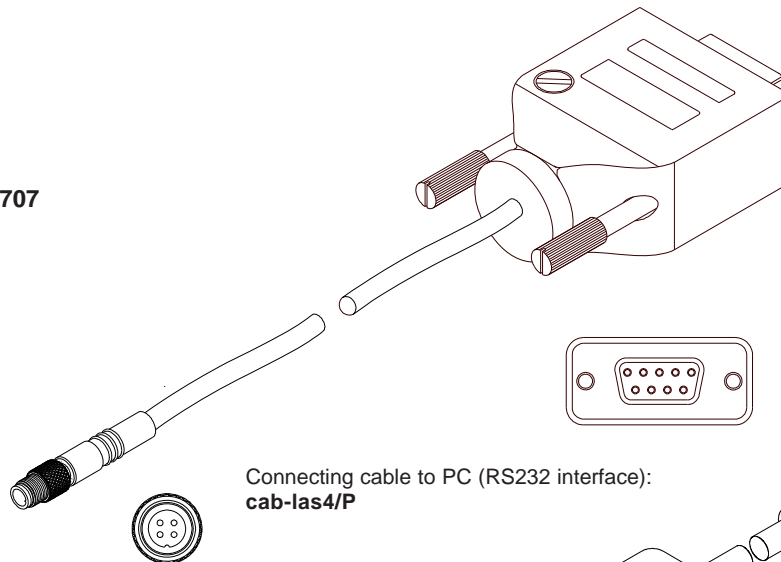

Connecting cable to PC (RS232 interface):  
**cab-las4/P**

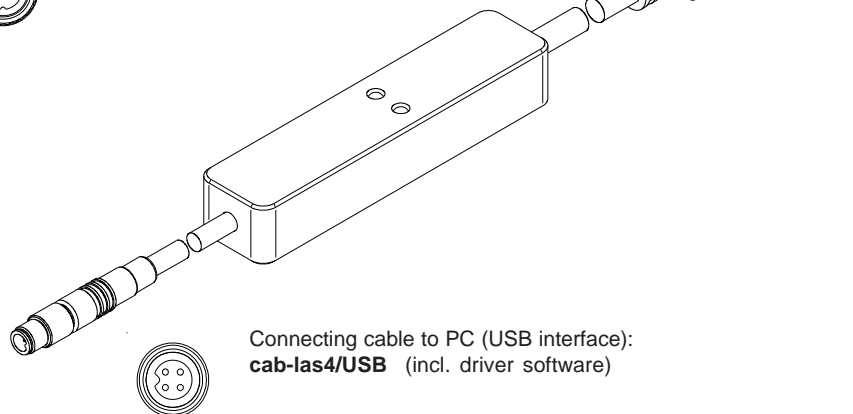

Connecting cable to PC (USB interface):  
**cab-las4/USB** (incl. driver software)

**Laser Warning**

The laser line sensors of L-LAS Series comply with laser class 2 according to EN 60825-1. The use of these laser transmitters therefore requires no additional protective measures.

The laser line sensors of L-LAS Series are supplied with a laser warning label.

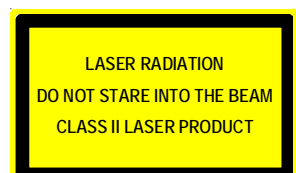



LED Display

- LED red (-)  
Measuring value < lower tolerance threshold
- LED green  
Measuring value within olerance window
- LED red (+)  
Measuring value > upper tolerance threshold

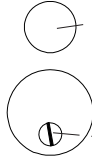

Potentiometer for tolerance setting

Teach button for set point teaching (input IN0)



Windows® Software

Windows® software L-LAS-GTM-Scope:

The L-LAS-GTM sensor can be easily parameterised with the Windows® user interface. For this purpose the sensor is connected to the PC with the serial interface cable cab-las4/PC.

When parameterisation is finished, the PC can be disconnected again.

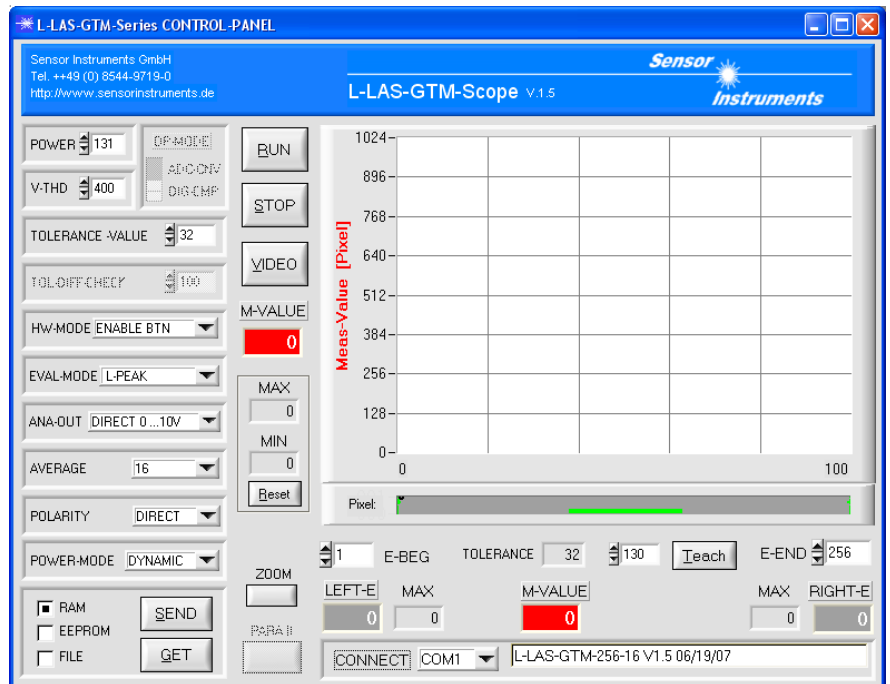



Application Examples

**Detecting both sides of a glass pane at a glance**

In glass processing it is of special importance - especially in case of surfaces that are coated on one side - to know on which side of the glass the additional layer has been applied. The additional layer(s) may have quite different tasks: The layer may be highly water-repellent (lotus effect), or it may reduce reflections (anti-reflection layer) or increase reflection (mirror-coated glass).

The L-LAS-GTM-256/16 sensor uses the reflection principle. Collimated (parallel) laser light (light spot dimensions 3 mm x 0.5 mm) is directed onto the glass surface at a certain angle (selectable by the user and depending on the distance between sensor and glass surface) and is partly reflected by the 1st surface, but the largest part of the laser light penetrates the glass pane and is then partly reflected at the back side of the glass (2nd surface). Compared to the 1st reflection there will be a parallel offset of the two laser beams due to the glass thickness.

Both laser beams impinge on a line detector that is integrated in the laser sensor. The line video signal is evaluated by an integrated controller. The ratio of the reflected light can then be determined from the amplitude of the peak in the video signal.



**Detection of glass coating**

In glass production the glass panes are coated on one side. The task is to check which side has been coated.

The glass pane was detected with an L-LAS-GTM-256/16 at a distance of approx. 20 mm.

Screen printout 1 shows the signal characteristic with the coating at the top, and screen printout 2 shows the signal characteristic with the coating at the bottom.

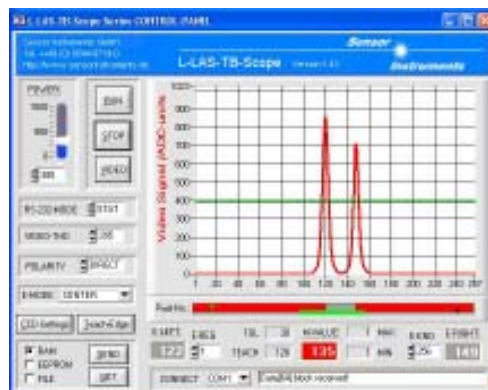

Picture 1: Signal characteristic with coating on the top

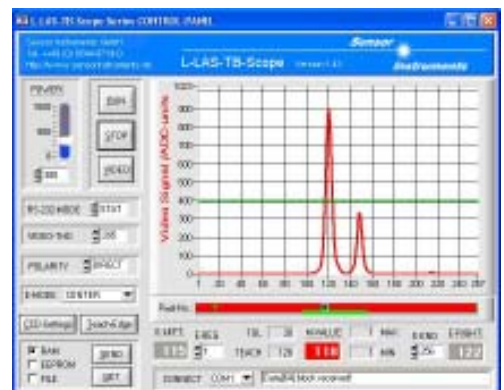

Picture 2: Signal characteristic with coating on the bottom