

Accessories

▶ C-MOUNT-LT-37

Mounting plate for Master/Slave line sensors
L-LAS-LT-37-MA/-SL or
L-LAS-LT-37-HS-MA/-SL

- Mounting plate in C-shape with several mounting holes
- Distance Master and Slave (optical axis) adjustable in 3 mm steps (symmetrically each side 1.5 mm): from min. 33.49 mm to max. 57.49 mm
- Sturdy material (aluminum, anodized in black)



Design

Product name:

C-MOUNT-LT-37

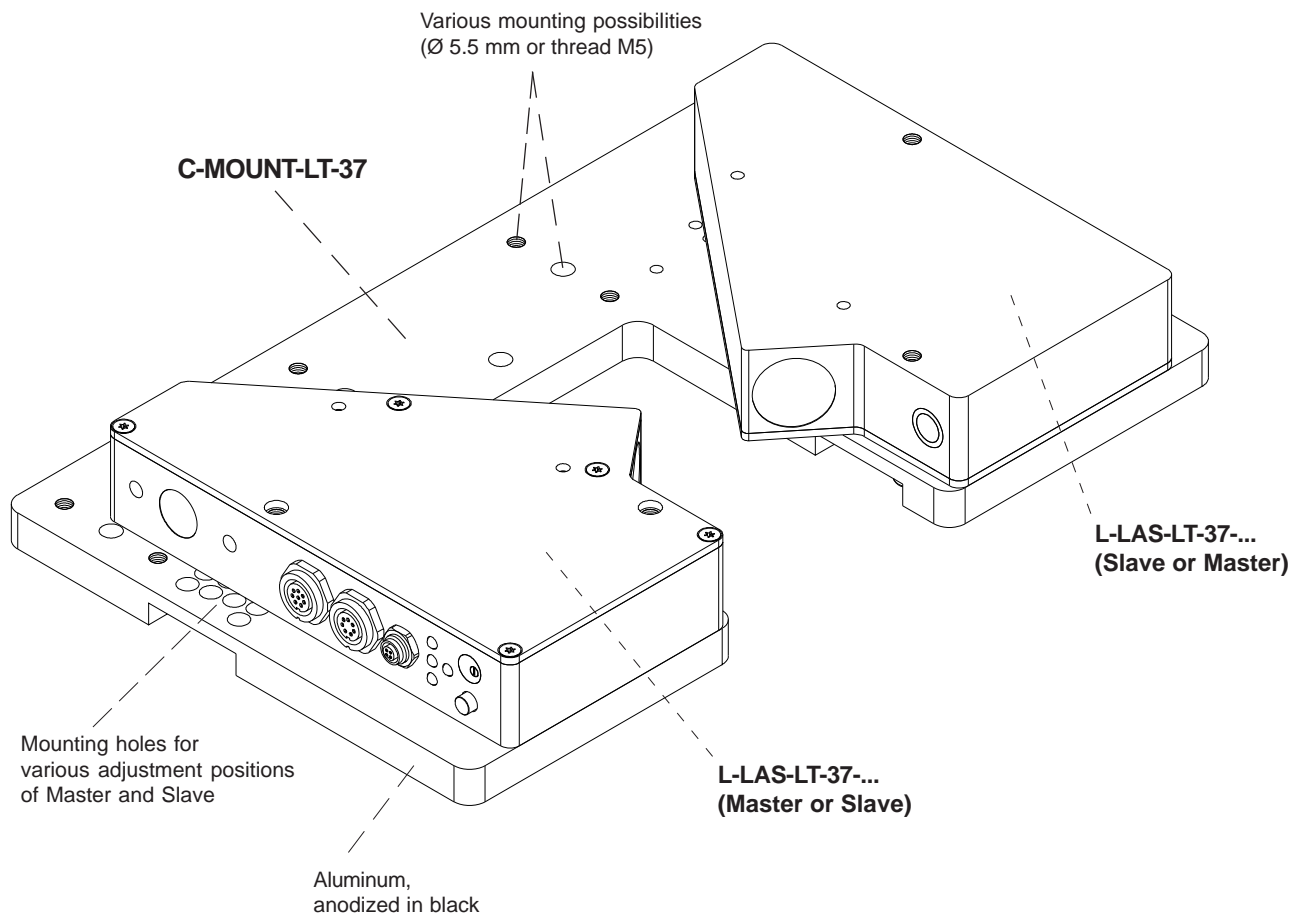



Adjustment Positions

Mounting plate C-MOUNT-LT-37

suitable for Master/Slave line sensors
L-LAS-LT-37-MA / -SL
L-LAS-LT-37-HS-MA / -SL

- Distance Master and Slave (optical axis) adjustable in 3 mm steps (symmetrically each side 1.5 mm): from min. 33.49 mm to max. 57.49 mm

Adjustment positions (cf. drawing on the next page):
E = Distance Master/Slave (optical axis) in mm

Adjustment position	A	B	C	D	E
1.	74	0	4	10	33.49
2.	77	0	7	16	36.49
3.	80	0	10	22	39.49
4.	83	5	13	28	42.49
5.	86	8	16	10	45.49
6.	89	11	19	16	48.49
7.	92	14	22	22	51.49
8.	95	17	25	28	54.49
9.	98	20	28	10	57.49

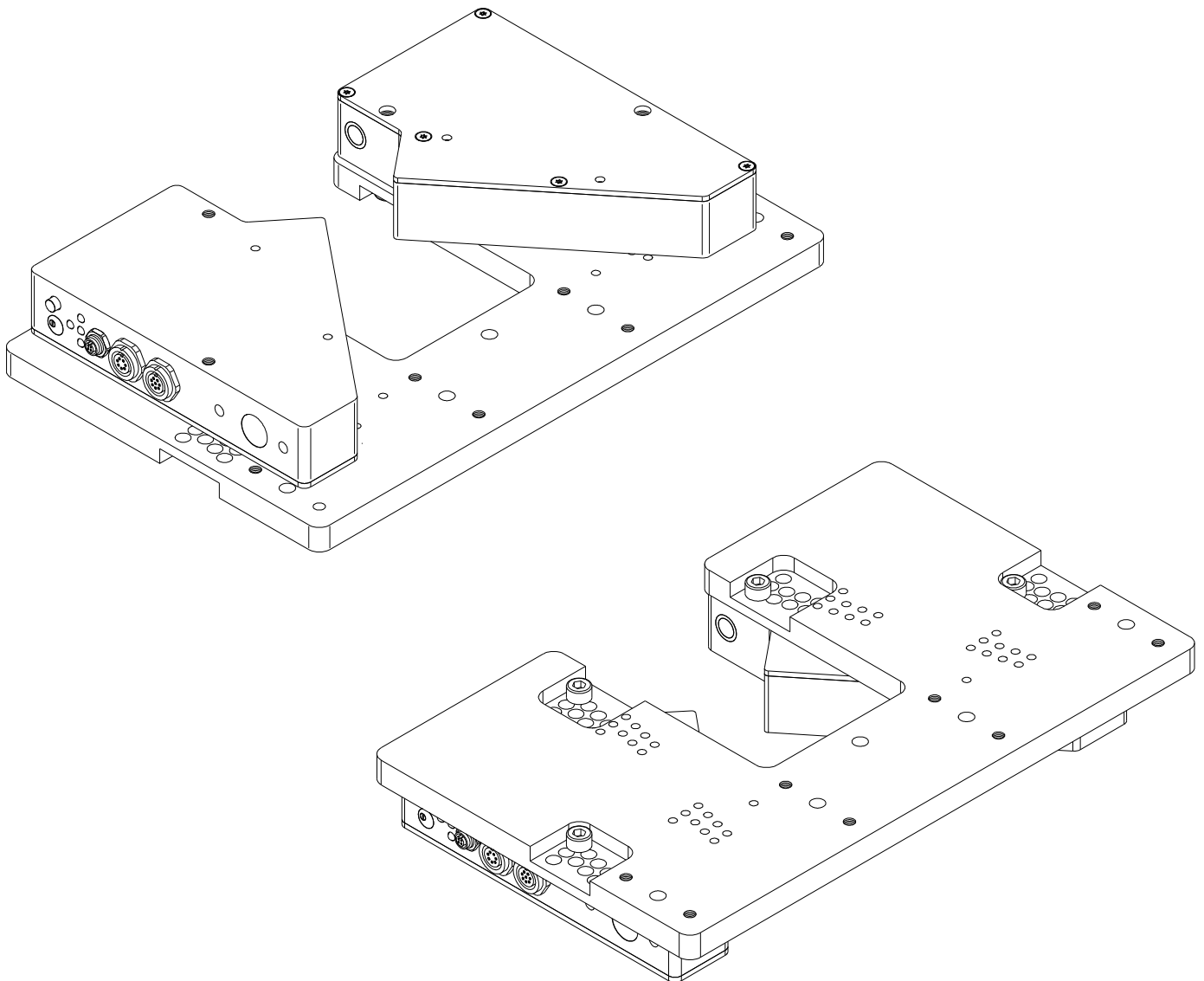

Dimensions

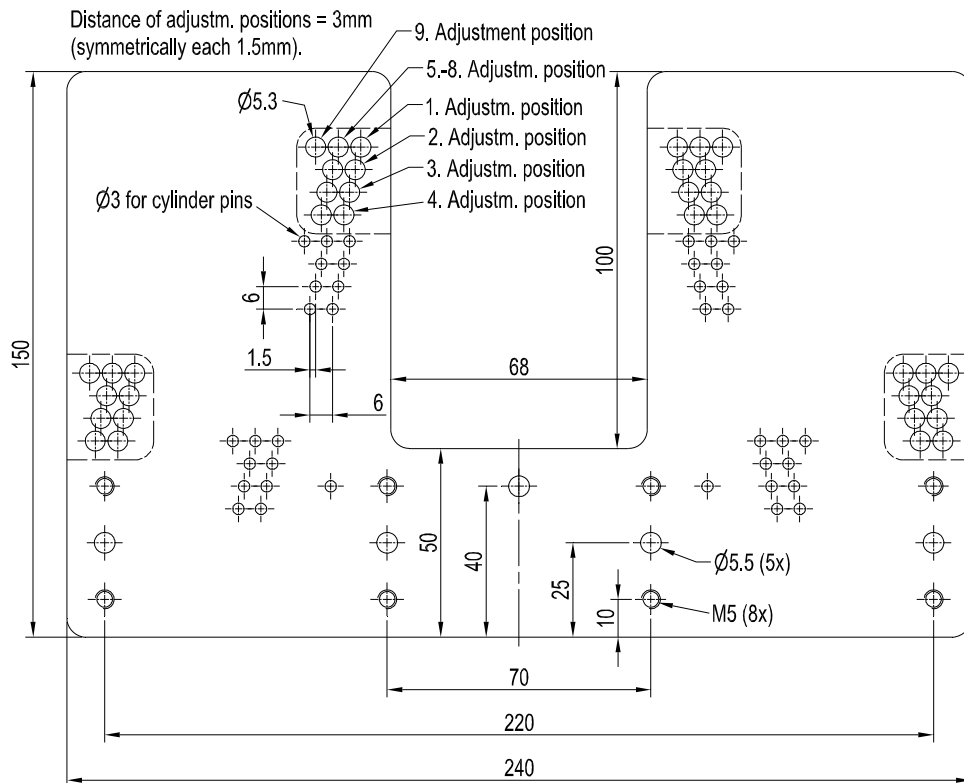
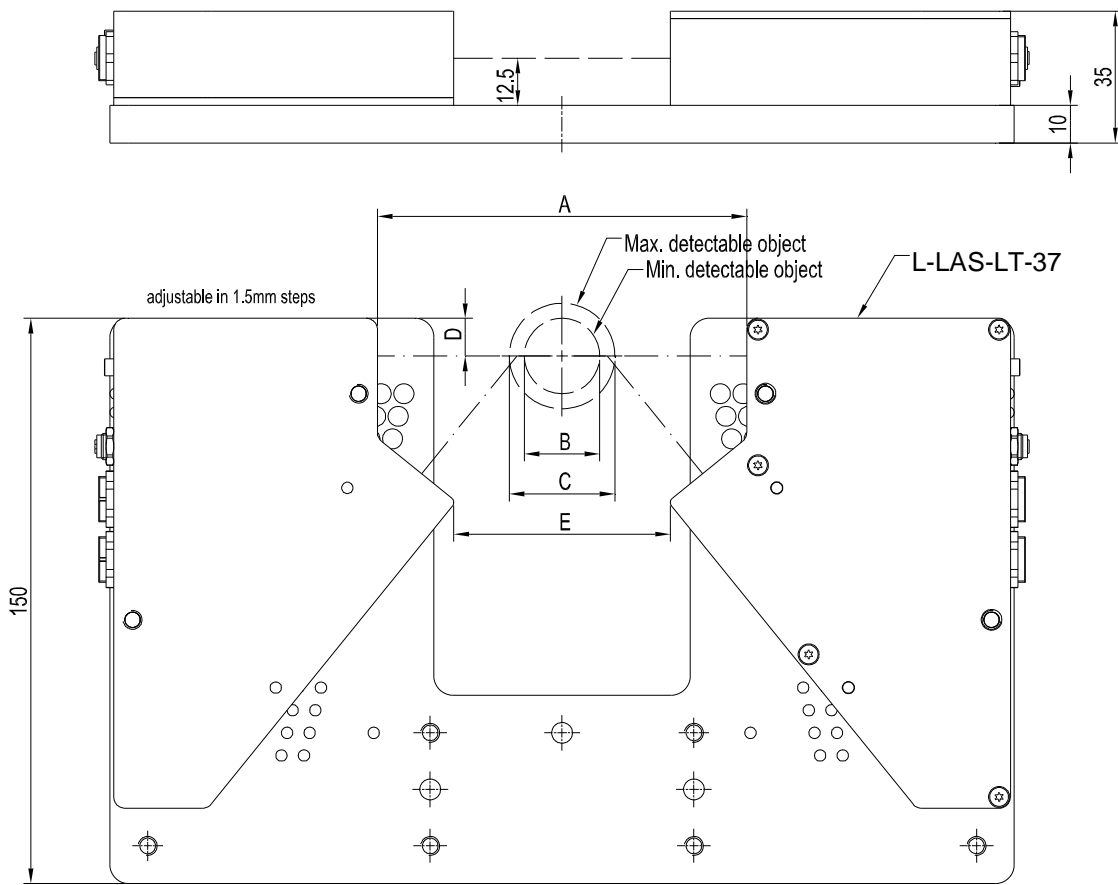

(All dimensions in mm)