

COAST Series

▶ COAST-85-45°/45°

- Recommended measurement distance: 85 mm ± 5 mm
- Big dynamic range due to focused white-light operation
- Two controllers in one sensor (color and gloss+structure)
- Up to 31 colors and up to 31 structure vectors can be stored
- RS232 interface (USB or Ethernet adapter is available)
- 2 ring light illuminations with each 9 super-bright white-light LEDs, focused (AC-, DC-, PULSE-operation or OFF for luminous objects can be switched)
- Evaluation of the forward and backward scattering (alternating, can be switched via input IN0)
- Color detection, contrast detection, gray scale detection as well as structure evaluation
- Insensitive to outside light (in AC- or PULSE-operation)
- Brightness correction can be activated (STAT/DYN)
- Several TEACH functions (via PC, PLC, or push button)
- Various evaluation algorithms can be activated
- "BEST HIT" mode ("human color assessment")
- Switching state display by means of 2x 5 yellow LEDs
- Parameterizable via Windows® software, scope function
- Temperature compensated
- 3-color filter detector (true color detector: "human color perception") and line detector (512 pixel)



Design

Product name:

COAST-85-45°/45°

(incl. Windows® PC software
SPECTRO3-Scope and STRUCT-Scope)

45°/45°: Optical axes of the two ring lights are inclined each at an angle of 45° from the vertical.

Several transmitter/receiver combinations are possible:

- IN0=1: Backward reflection + color sensor
Forward reflection + structure sensor
- IN0=0: Forward reflection + color sensor
Backward reflection + structure sensor

8-pole fem. conn.
Binder Series 712
(connection of
color sensor to PLC)

Connecting cable:
cab-las8/SPS

TEACH button
(external teaching
of color sensor
via input IN0)

LED display:
Switching state
indication for
color sensor
by means of 5
yellow LED)

4-pole fem. conn.
Binder Series 707
(connection of color
sensor to PC)

Connecting cable:
cab-las4/PC or
cab-4/USB or
cab-4/ETH

Mounting possibilities
(threaded M5 or
Ø 9.2 mm)

Optics holding device
(aluminum, anodized),
scratch-resistant optics
cover made of glass

Receiver optics with
3-color filter detector
(True Color), trans-
mitter optics with
9 white-light LED

Receiver optics with fixed aperture
and line detector, transmitter optics
with 9 white-light LED

Optics holding device
(aluminum, anodized),
scratch-resistant optics
cover made of glass

Sturdy aluminum
housing, anodized
in black

4-pole fem. conn.
Binder Series 707
(connection of
structure sensor to
PC)

Connecting cable:
cab-las4/PC or
cab-4/USB or
cab-4/ETH

8-pole fem. conn.
Binder Series 712
(connection of
structure sensor to
PLC)

Connecting cable:
cab-las8/SPS

LED display:
Switching state indication
for structure sensor
by means of 5 yellow LED)



Technical Data

Model	COAST-85-45°/45°
Voltage supply	+24VDC (± 10%), reverse polarity protected, overcurrent protected
Current consumption	< 500 mA
Max. switching current	100 mA, short circuit proof
Switching state indication (each 5x LED)	Color sensor: 5 yellow LED visualize the physical state of the outputs OUT0 ... OUT4 Structure sensor: 5 yellow LED visualize the physical state of the outputs OUT0 ... OUT4
Input digital (each 1x)	Color sensor: 1 digital input: IN0 (Pin 3), digital (0V/+24V) or teach button at the housing Structure sensor: 1 digital input: IN0 (Pin 3), digital (0V/+24V) The digital inputs IN0 of color sensor and structure sensor are connected internally
Outputs digital (each 5x)	Color sensor: OUT0...OUT4 (Pin 4..8): digital (0V/+24V), pn-/pnp-able (bright-/dark-switching, can be switched) Structure sensor: OUT0...OUT4 (Pin 4..8): digital (0V/+24V), pn-/pnp-able (bright-/dark-switching, can be switched)
Interface (each 1x)	Color sensor: RS232, structure sensor: RS232
Pulse lengthening	Color sensor: 0 ... 100 ms (adjustable via PC software), structure sensor: 100 ms ... 1 s (adjustable via PC software)
Averaging	max. 32768 values, adjustable via PC software
Scan frequency (alternating light operation/direct light operation)	LED operation, can be switched via PC software: AC operation: max. 20 kHz (depends on parameterization) DC and OFF operation: max. 35 kHz (depends on parameterization) PULSE operation: max. 5 kHz (depends on parameterization)
Max. measuring frequency	Color sensor: typ. 10 kHz (AC), structure sensor: typ. 10 Hz
Angle of incidence	Optical axes of the two ring lights are inclined each at an angle of 45° from the normal (vertical)
Measuring distance	typ. 85 mm ± 5 mm
Transmitter (light source)	2 optics with each 9 super-bright white-light LED, focused
Transmitter control	Can be switched via PC software: AC operation (LED MODE-AC), DC operation (LED MODE-DC)
Receiver	Color sensor: 3-color filter detector (TRUE COLOR, "human color perception"), color filter curves acc. to CIE 1931 structure sensor: line detector, 512 pixel
Receiver gain setting respectively exposure time	Color sensor: 8 steps (AMP1 ... AMP8), adjustable via PC software + INTEGRAL (software implemented addition of consecutive values) Structure sensor: software implemented adjustment of exposure time (EXPOSURE TIME)
Ambient light	max. 5000 Lux
Detection range	Color sensor: half intensity width typ. Ø 20 mm at a distance of 85 mm Structure sensor: measuring length typ. 20 mm at a distance of 85 mm
Reproducibility	Color sensor: in the X, Y color range each 1 digit at 12-bit A/D conversion, structure sensor: 20mm/512
Temperature drift X,Y	$\Delta X/\Delta T; \Delta Y/\Delta T$ typ. 0.2 digits/°C (< 0.01% / °C)
Resolution	Color sensor: $\Delta E \geq 0.5$, structure sensor: 20mm/4096
Color space (color sensor)	X Y INT siM (Lab)
Memory capacity	Color sensor: non-volatile EEPROM with parameter sets for max. 31 colors Structure sensor: max. 8 spatial frequency spectra (max. 31 structure vectors)
Housing dimensions	LxWxH approx. 204.3 mm x 108 mm x 33.8 mm, without connectors
Housing material	Aluminum, anodized in black (optics holding device: aluminum, anodized)
Enclosure rating	IP64
Connecting cables	2x to PLC: cab-las8/SPS or cab-las8/SPS-w (each 1x for color sensor and for structure sensor) 2x to PC/RS232 interface: cab-las4/PC or cab-las4/PC-w (each 1x for color sensor and for structure sensor) alternatively: 2x to PC/USB-interface: cab-4/USB or cab-4/USB-w alternatively: 2x to PC/Ethernet-interface: cab-4/ETH
Type of connector	Connection to PLC: 8-pole fem. connector (Binder 712), connection to PC: 4-pole fem. connector (Binder 707)
Temperature ranges	Operating temperature range: -20°C ... +55°C, storage temperature range: -20°C ... +85°C
EMC test acc. to	DIN EN 60947-5-2

Dimensions

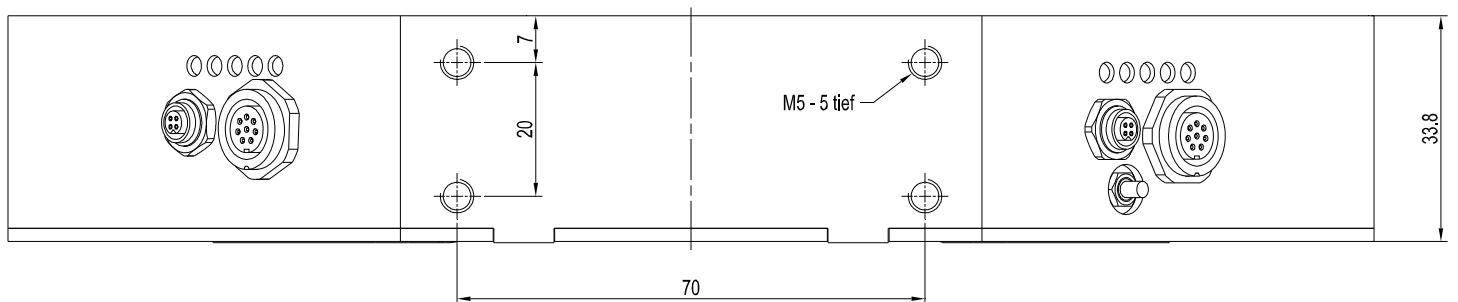
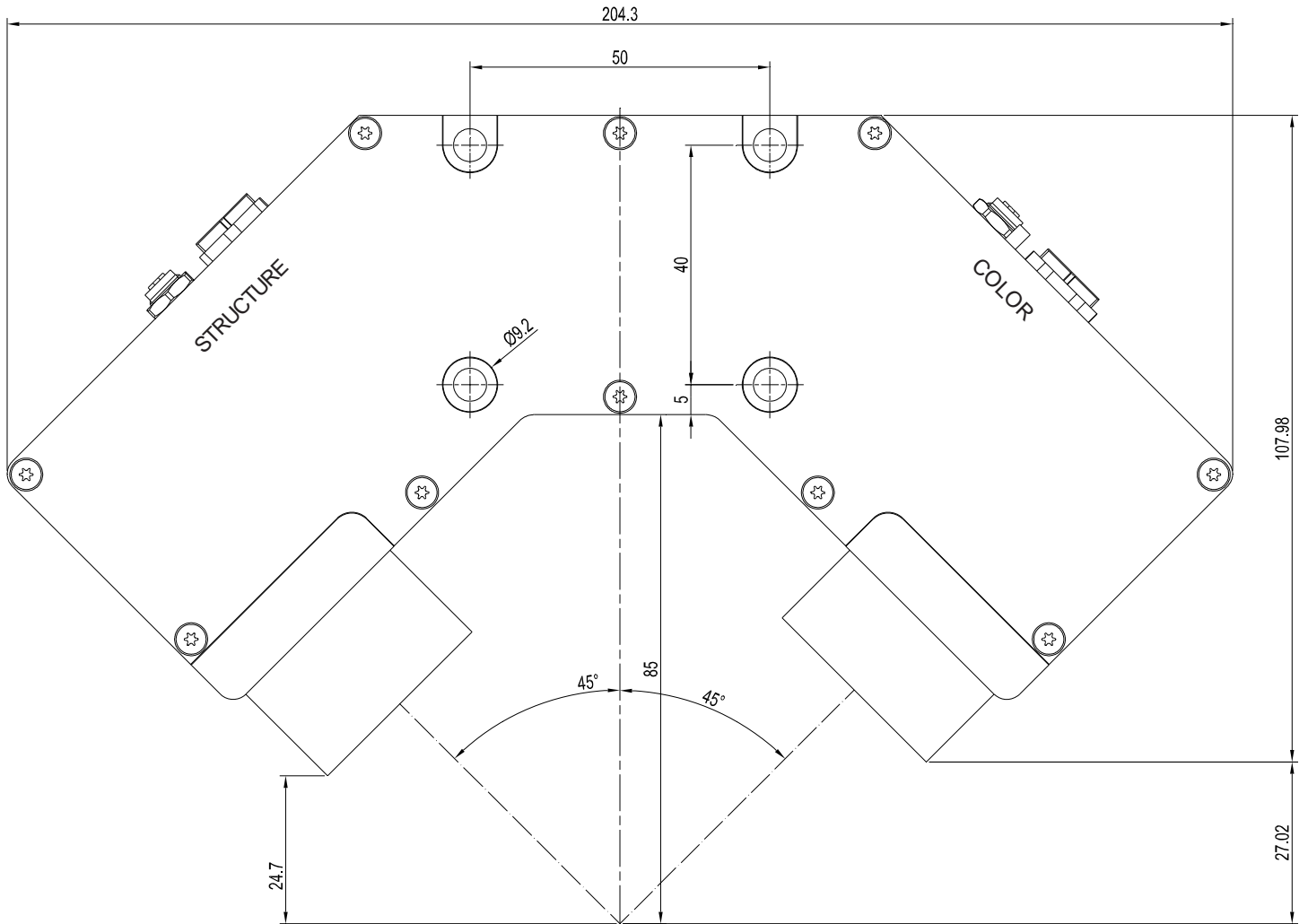

All dimensions in mm

Connector Assignment

Connector assignment of color sensor (COLOR side):**Connection to PLC:****8-pole fem. connector Binder Series 712**

Pin:	Color:	Assignment:
1	white	GND (0V)
2	brown	+24VDC ($\pm 10\%$)
3	green	IN0
4	yellow	OUT0
5	grey	OUT1
6	pink	OUT2
7	blue	OUT3
8	red	OUT4

Connecting cable:

cab-las8/SPS-(length)
 cab-las8/SPS-w-(length) (angle type, 90°)
 (standard length 2m)

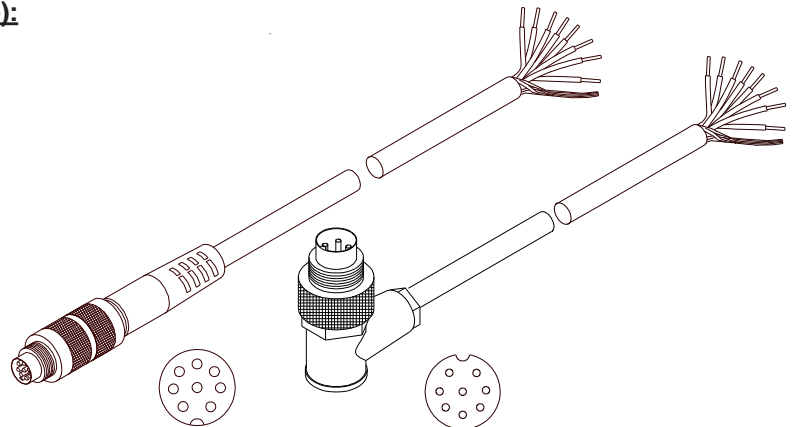

cab-las8/SPS-...
 (max. length 25m, outer jacket: PUR)

cab-las8/SPS-w-...
 (max. length 25m, outer jacket: PUR)

Connection to PC:**4-pole fem. connector Binder Series 707**

Pin:	Assignment:
1	+24VDC (+Ub, OUT)
2	GND (0V)
3	RxD
4	TxD

Connection via RS232 interface at the PC:

Connecting cable:
 cab-las4/PC-(length)
 cab-las4/PC-w-(length) (angle type 90°)
 (standard length 2m)

alternative:**Connection via USB interface at the PC:**

Connecting cable (incl. driver software):
 cab-4/USB-(length)
 cab-4/USB-w-(length) (angle type 90°)
 (standard length 2m)

alternative:**Connection to local network via Ethernet bus:**

Adapter (incl. software „SensorFinder“):
 cab-4/ETH-500
 (standard length 0.5m)

Optional: External CAT5 cable, e.g.
 cab-eth/M12D-RJ45-flx-(length)

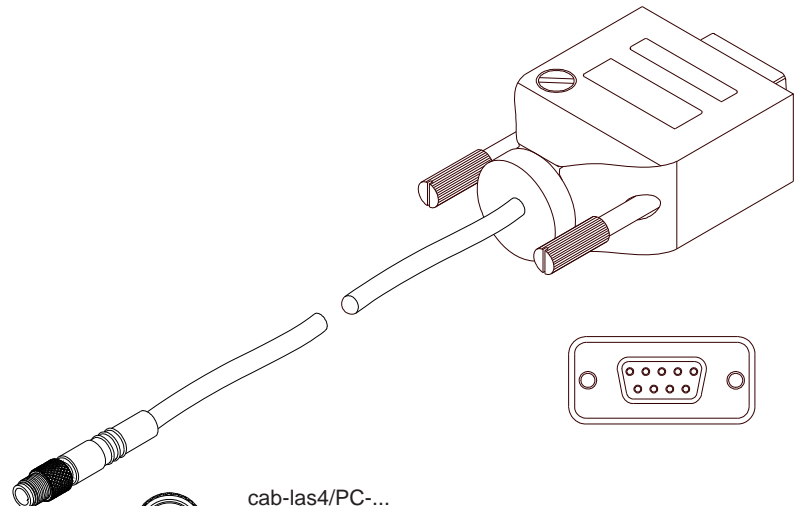

cab-las4/PC-...
 (max. length 10m, outer jacket: PUR) or
 cab-las4/PC-w-... (no picture)
 (max. length 5m, outer jacket: PUR)

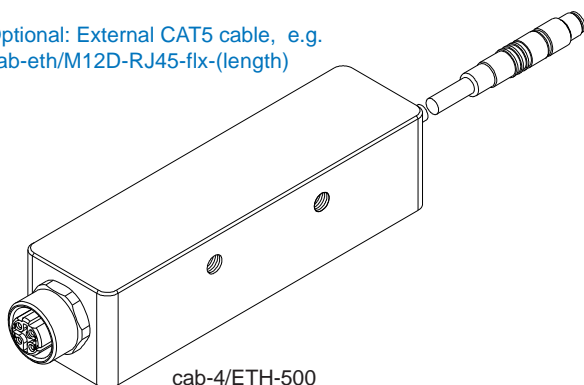

cab-4/ETH-500
 (length 0.5m, outer jacket: PUR)
 4-pole M12 fem. conn. (D-coded)
 for connection of an external
 CAT5 cable, e.g.
 cab-eth/M12D-RJ45-flx-(length)

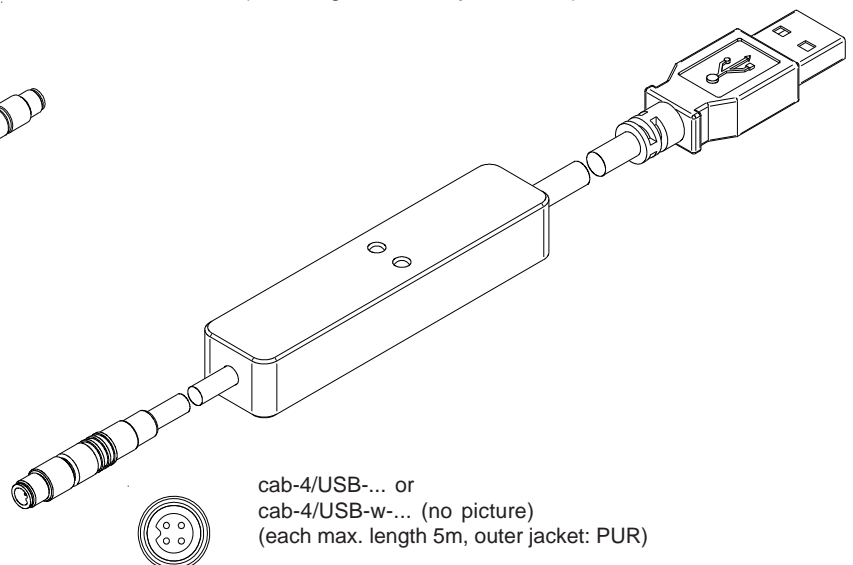

cab-4/USB-... or
 cab-4/USB-w-... (no picture)
 (each max. length 5m, outer jacket: PUR)



Connector Assignment

Connector assignment of structure sensor (STRUCTURE side):

Connection to PLC:

8-pole fem. connector Binder Series 712

Pin:	Color:	Assignment:
1	white	GND (0V)
2	brown	+24VDC ($\pm 10\%$)
3	green	IN0
4	yellow	OUT0
5	grey	OUT1
6	pink	OUT2
7	blue	OUT3
8	red	OUT4

Connecting cable:
 cab-las8/SPS-(length)
 cab-las8/SPS-w-(length) (angle type, 90°)
 (standard length 2m)

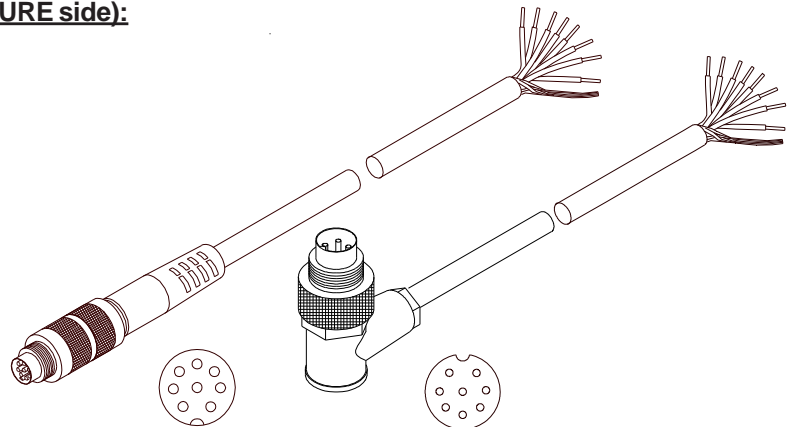

cab-las8/SPS-...
 (max. length 25m, outer jacket: PUR)

cab-las8/SPS-w-...
 (max. length 25m, outer jacket: PUR)

Connection to PC:

4-pole fem. connector Binder Series 707

Pin:	Assignment:
1	+24VDC (+Ub, OUT)
2	GND (0V)
3	RxD
4	TxD

Connection via RS232 interface at the PC:

Connecting cable:
 cab-las4/PC-(length)
 cab-las4/PC-w-(length) (angle type 90°)
 (standard length 2m)

alternative:

Connection via USB interface at the PC:

Connecting cable (incl. driver software):
 cab-4/USB-(length)
 cab-4/USB-w-(length) (angle type 90°)
 (standard length 2m)

alternative:

Connection to local network via Ethernet bus:

Adapter (incl. software „SensorFinder“):
 cab-4/ETH-500
 (standard length 0.5m)

Optional: External CAT5 cable, e.g.
 cab-eth/M12D-RJ45-flx-(length)

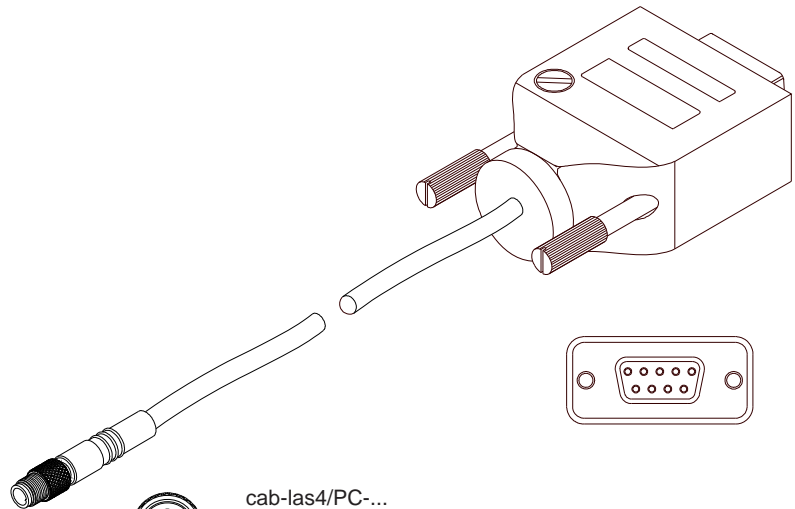

cab-las4/PC-...
 (max. length 10m, outer jacket: PUR) or
 cab-las4/PC-w-... (no picture)
 (max. length 5m, outer jacket: PUR)

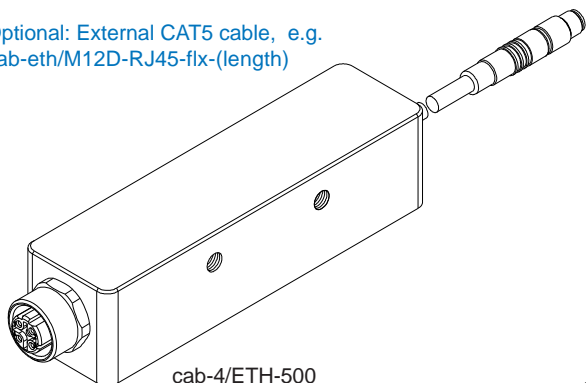

cab-4/ETH-500
 (length 0.5m, outer jacket: PUR)
 4-pole M12 fem. conn. (D-coded)
 for connection of an external
 CAT5 cable, e.g.
 cab-eth/M12D-RJ45-flx-(length)

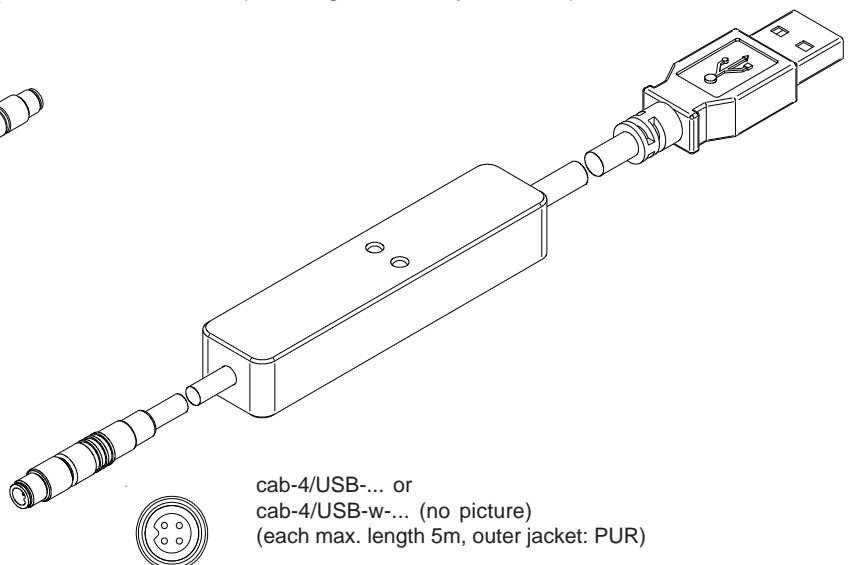

cab-4/USB-... or
 cab-4/USB-w-... (no picture)
 (each max. length 5m, outer jacket: PUR)



Measuring Principle

Measuring principle of COAST series sensors:

The COAST sensor (COlor And STructure sensor) is a hybrid sensor that comprises two sensors that only are synchronised by the LED ring light but otherwise operate independently of each other. Both sensors can be connected to a PLC or to a PC. One of the two sensors (color sensor) provides information about the color and gloss of the object to be inspected, while the other sensor (structure sensor) checks the structure of the surface.

Measuring principle of the color sensor:

The SPECTRO-3 provides highly flexible signal acquisition. For example, the sensor can be operated in alternating-light mode (AC mode), which makes the sensor insensitive to extraneous light. It also can be set to constant-light mode (DC mode), which makes the sensor extremely fast and allows a scan-frequency of up to 35 kHz. An OFF function turns off the integrated light source at the sensor and changes to DC operation. The sensor then can detect so-called "self-luminous objects". In PULSE operation extremely dark surfaces can be reliably detected. With the stepless adjustment of the integrated light source as well as the selectable gain of the receiver signal and an INTEGRAL function the sensor can be set to almost any surface or any "self-luminous object".

When the integrated light source of the SPECTRO-3 color sensor is activated, the sensor detects the radiation that is diffusely reflected from the object. As a light source the SPECTRO-3 color sensor uses a white-light LED with adjustable transmitter power. An integrated 3-fold receiver for the red, green, and blue content of the light that is reflected from the object, or the light that is emitted by a "self-luminous object", is used as a receiver.

The SPECTRO-3 color sensor can be "taught" up to 31 colors. For each of these taught colors it is possible to set tolerances. In "X Y INT - 2D" or "s i M - 2D" mode these tolerances form a color cylinder in space. In "X Y INT - 3D" or "s i M - 3D" mode the tolerances form a color sphere in space. Color evaluation according to "s i M - 2D" is based on the lab calculation method. All modes can be used in combination with several operating modes such as "FIRST HIT" and "BEST HIT". Raw data are represented with 12 bit resolution.

As a special feature the sensor can be taught two completely independent parameter sets. Input IN0 can then be used to tell the sensor which parameter set it should work with.

Color detection either operates continuously or is started through an external PLC trigger signal. The respective detected color either is provided as a binary code at the 5 digital outputs or can be sent directly to the outputs, if only up to 5 colors are to be detected. At the same time the detected color code is visualised by means of 5 LEDs at the housing of the SPECTRO-3.

With a TEACH button at the sensor housing the color sensor can be taught up to 31 colors. For this purpose the corresponding evaluation mode must be set with the software. The TEACH button is connected in parallel to the input IN0 (green wire at cable cab-las8/SPS).

Parameters and measurement values can be exchanged between a PC and the SPECTRO-3 color sensor through the serial RS232 interface. All the parameters for color detection also can be saved to the non-volatile EEPROM of the SPECTRO-3 color sensor through this serial RS232 interface. When parameterisation is finished, the color sensor continues to operate with the current parameters in STAND-ALONE mode without a PC.

The sensors of the SPECTRO-3 series can be calibrated (white-light balancing). Balancing can be performed to any white surface. A ColorChecker™ table with 24 color fields is available as an alternative. White-light balancing or calibration can be performed to one of the white fields.



Measuring Principle

Measuring principle of the color sensor:

The ring light can be switched over (forward scattering light / backward scattering light) by way of input INØ:

IN0 = 1
Backward reflection is used
(viewed from the color sensor)

With the PARA mode (see page 15)
the color sensor through IN0 can
be operated with parameters that
can be independently set for
forward and backward reflection.

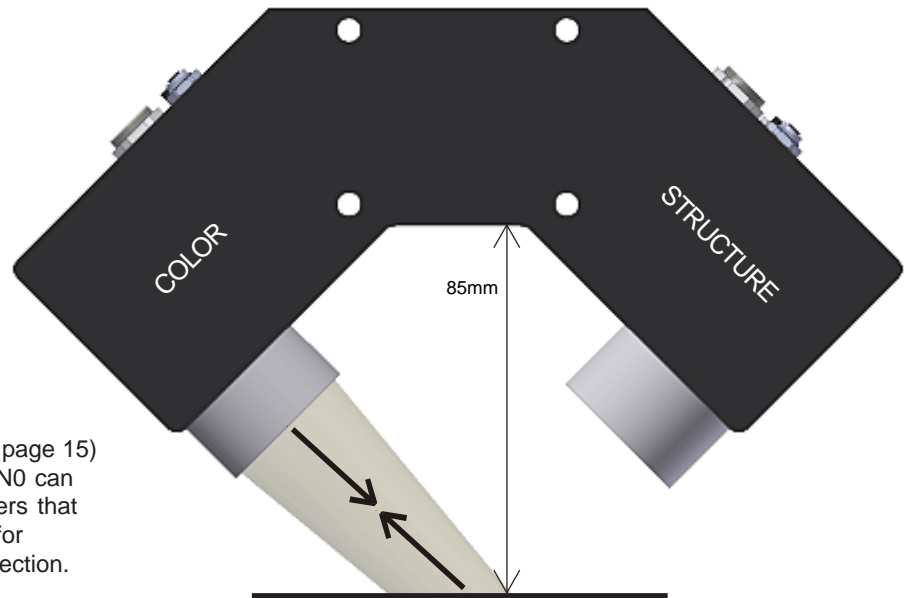

IN0 = 0
Forward reflection is used
(viewed from the color sensor)

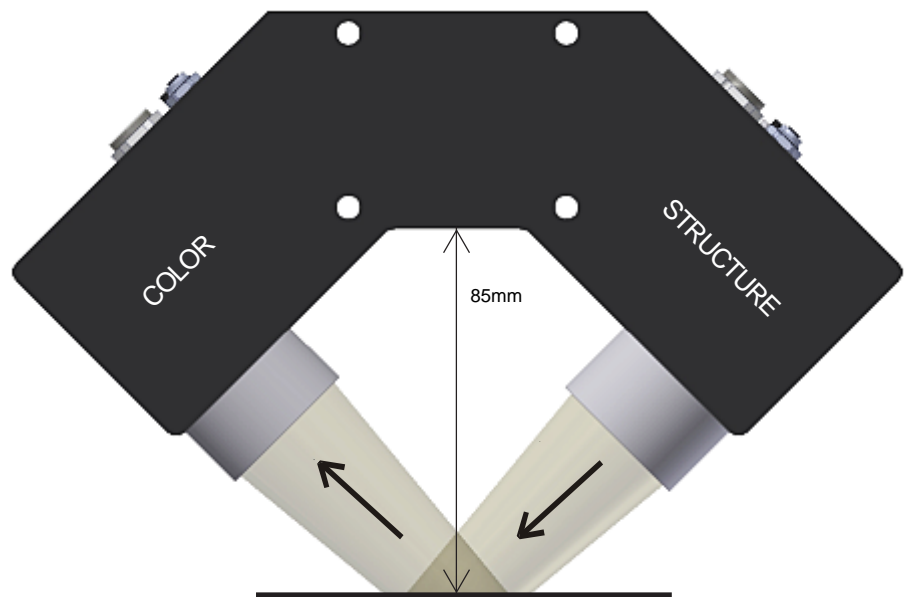



Measuring Principle

Measuring principle of the structure sensor:

The structure sensor in principle is a line camera that features two independently controllable ring-light LED sources (that can be selected through IN0). The detection range (line) is 20 mm at a distance of 85 mm from the sensor body (see dimensions) and runs crosswise to the longitudinal direction of the sensor. The line-shaped section of the surface to be inspected (approx. 20 mm x 0.5 mm) is mapped on the line detector by the projection lens (receiver optics). By way of suitable algorithms the video signal generated by the line detector is converted into a structure signal (spatial frequency spectrum) by the sensor's internal controller. This means that a signal is thus available that provides information about the structure of the surface.

For each LED light (forward reflection, backward reflection) up to 8 spatial frequency spectrums or up to 31 structures can be stored in the sensor. For inspection the current spatial frequency spectrum (structure signal) is compared with the spatial frequency spectrums (depending on IN0 = 1 or 0) stored in the memory, and the most similar spatial frequency spectrum is searched (similar to the BESTHIT method of the color sensor).

As with the color sensor, parameters for the structure sensor also can be changed through IN0 (**PARA mode**):

IN0 = 1
Forward reflection is used
(viewed from the structure sensor)

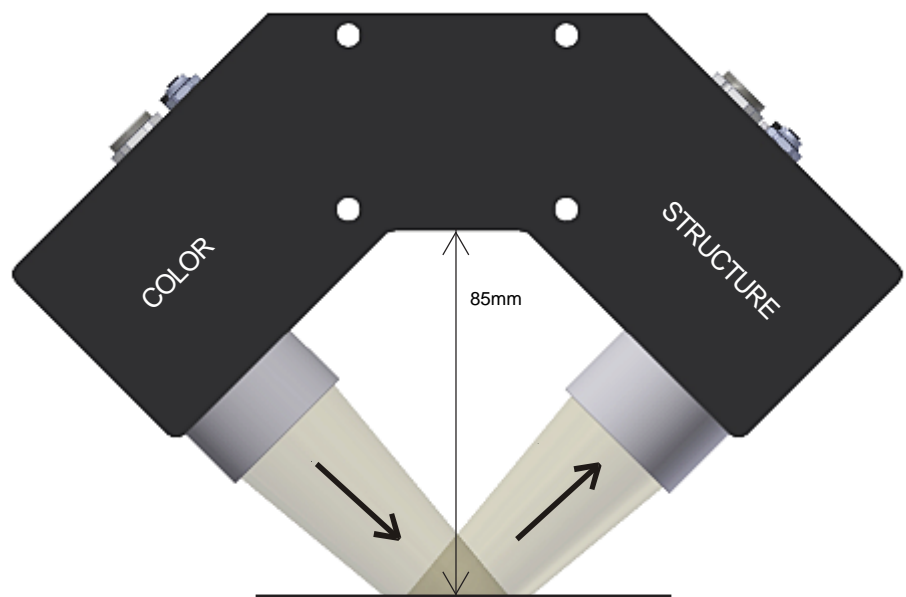

IN0 = 0
Backward reflection is used
(viewed from the structure sensor)

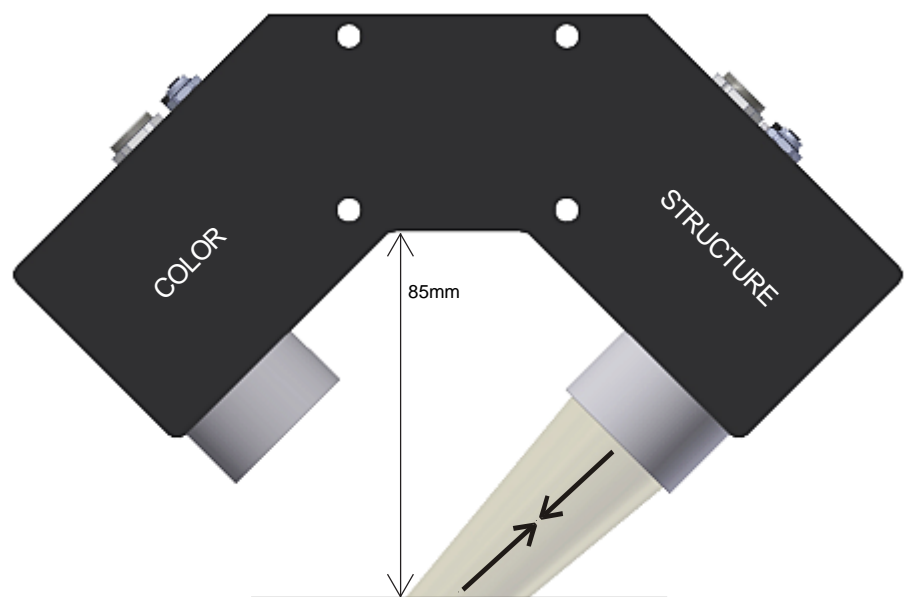



Visualization of color code (COLOR side) and structure code (STRUCTURE side):

The color code is visualized by means of 5 yellow LEDs at the housing of the COAST sensor. The color code that is indicated at the LED display simultaneously is provided in binary mode (OUT BINARY) as 5-bit binary information at digital outputs OUT0 ... OUT4 of the 8-pole PLC connector at the COLOR side.

The COAST sensor is able to process a maximum of 31 colors (color code 0 ... 30) corresponding to the individual rows in the COLOR TEACH TABLE. The color sensor indicates an "error" or a "not detected color" by turning on all the LEDs (digital outputs OUT0 ... OUT4 at HIGH level).

The structure sensor can store a maximum of 8 structures each for correlation evaluation (8 for IN0 = 0 and 8 for IN0 = 1) as well as a maximum of 31 structure vectors.

A maximum of 5 teach colors (no. 0, 1, 2, 3, 4) are permitted in DIRECT mode (OUT DIRECT HI or OUT DIRECT LO). If the selector switch is set to DIRECT HI, the corresponding digital output is HI and the other four are LO. If no color was detected, the digital outputs are in LO state (no LED is on).

If the selector switch is set to DIRECT LO, the corresponding digital output is LO and the other four are HI. If no color was detected, the digital outputs are in HI state (all LEDs are on).

COLOR side:

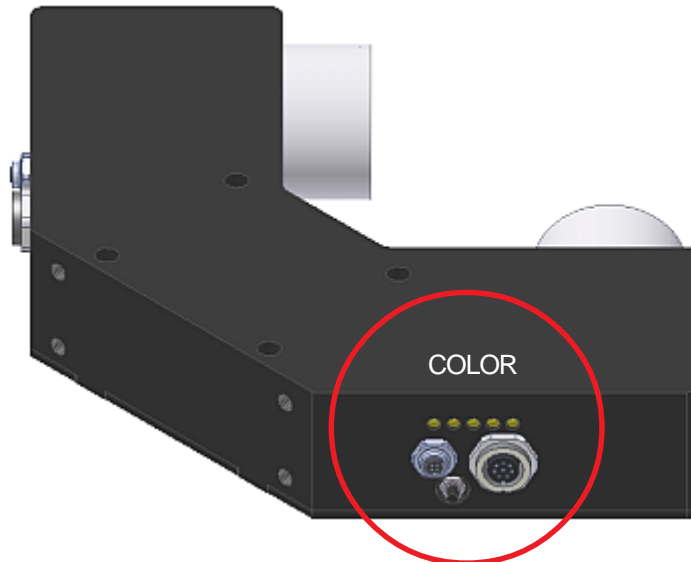

STRUCTURE side:

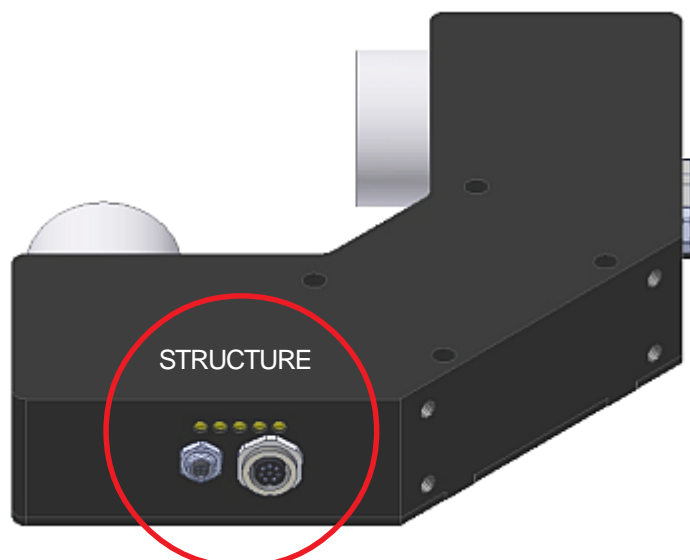



LED Display

LED display color sensor (COLOR side):

The color code is visualized by means of 5 yellow LEDs at the housing of the color sensor. At the same time the color code indicated at the LED display is output as 5-bit binary information at the digital outputs OUT0 ... OUT4 of the 8-pole PLC connector.

In the DIRECT mode the maximum number of color codes to be taught is 5. These 5 color codes can be directly output at the 5 digital outputs. The respective detected color code is displayed by means of the 5 yellow LEDs at the color sensor housing.

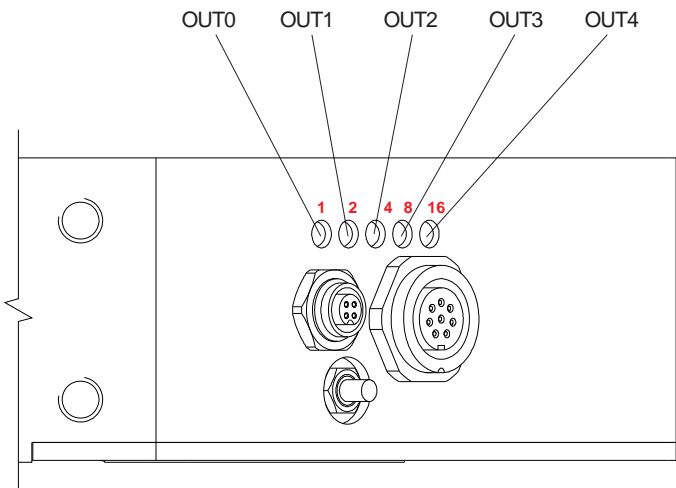
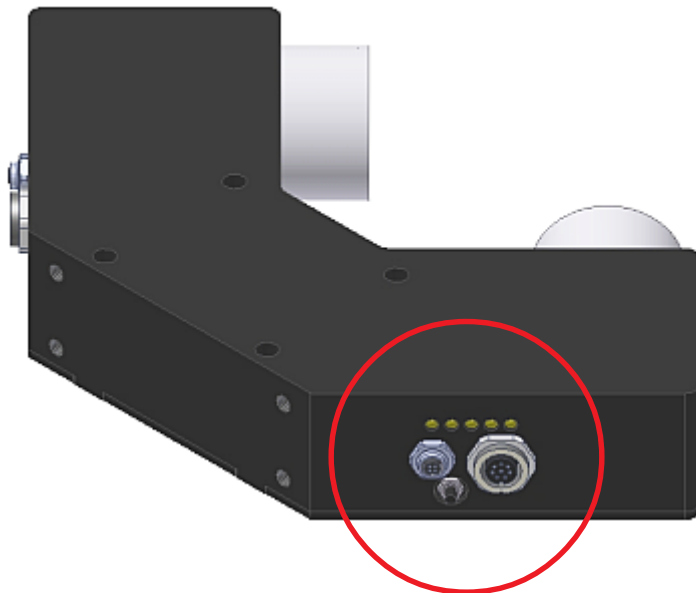

○ ○ ○ ○ ○ 0	● ○ ○ ○ ○ 1	○ ● ○ ○ ○ 2
● ● ○ ○ ○ 3	○ ○ ● ○ ○ 4	● ○ ● ○ ○ 5
○ ● ● ○ ○ 6	● ● ● ○ ○ 7	○ ○ ○ ● ○ 8
● ○ ○ ● ○ 9	○ ● ○ ● ○ 10	● ● ○ ● ○ 11
○ ○ ● ● ○ 12	● ○ ● ● ○ 13	○ ● ● ● ○ 14
● ● ● ○ ○ 15	○ ○ ○ ○ ● 16	● ○ ○ ○ ● 17
○ ● ○ ○ ● 18	● ● ○ ○ ● 19	○ ○ ● ○ ● 20
● ○ ● ○ ● 21	○ ● ● ○ ● 22	● ● ● ○ ● 23
○ ○ ○ ● ● 24	● ○ ○ ● ● 25	○ ● ○ ● ● 26
● ● ○ ● ● 27	○ ○ ● ● ● 28	● ○ ● ● ● 29
○ ● ● ● ● 30	● ● ● ● ● Error or „not detected“	



LED Display

LED display structure sensor (STRUCTURE side):

The structur vector is visualized by means of 5 yellow LEDs at the housing of the structure sensor. At the same time the structure vector indicated at the LED display is output as 5-bit binary information at the digital outputs OUT0 ... OUT4 of the 8-pole PLC connector.

In the DIRECT mode the maximum number of structure vectors to be taught is 5. These 5 structure vectors can be directly output at the 5 digital outputs. The respective detected structure vector is displayed by means of the 5 yellow LEDs at the structure sensor housing.

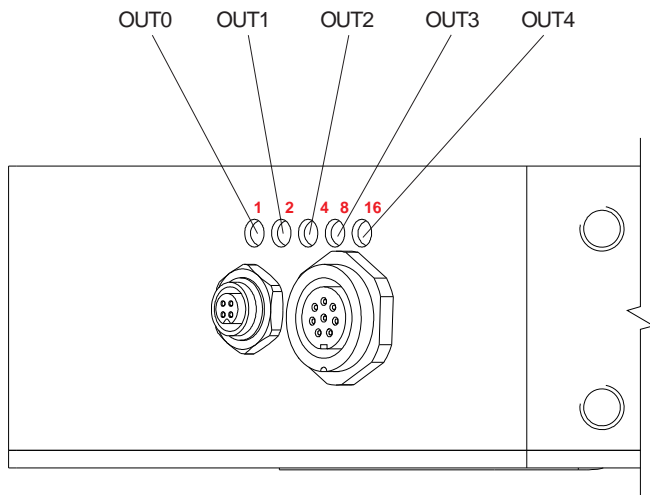
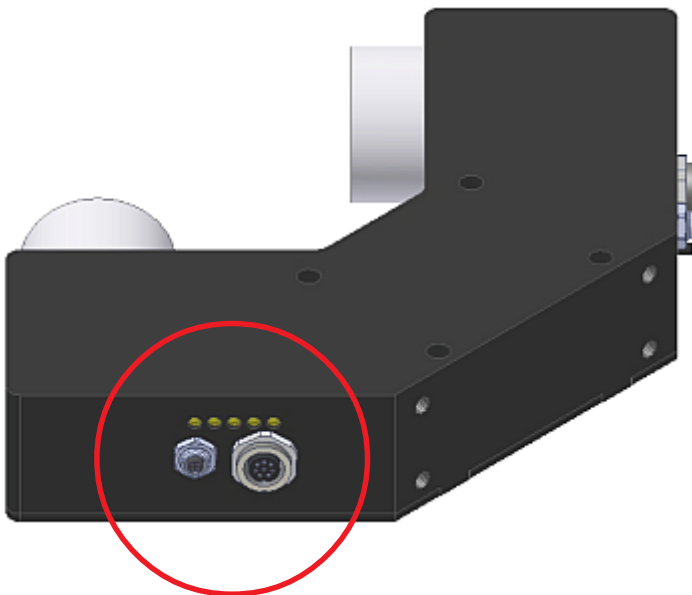

○ ○ ○ ○ ○ 0	● ○ ○ ○ ○ 1	○ ● ○ ○ ○ 2
● ● ○ ○ ○ 3	○ ○ ● ○ ○ 4	● ○ ● ○ ○ 5
○ ● ● ○ ○ 6	● ● ● ○ ○ 7	○ ○ ○ ● ○ 8
● ○ ○ ● ○ 9	○ ● ○ ● ○ 10	● ● ○ ● ○ 11
○ ○ ● ● ○ 12	● ○ ● ● ○ 13	○ ● ● ● ○ 14
● ● ● ○ ○ 15	○ ○ ○ ○ ● 16	● ○ ○ ○ ● 17
○ ● ○ ○ ● 18	● ● ○ ○ ● 19	○ ○ ● ○ ● 20
● ○ ● ○ ● 21	○ ● ● ○ ● 22	● ● ● ○ ● 23
○ ○ ○ ● ● 24	● ○ ○ ● ● 25	○ ● ○ ● ● 26
● ● ○ ● ● 27	○ ○ ● ● ● 28	● ○ ● ● ● 29
○ ● ● ● ● 30	● ● ● ● ● Error or „not detected“	



Parameterization

Windows® user interface:

The COAST sensor is parameterized under Windows® with the SPECTRO3-Scope software as well as the STRUCT-Scope software. The Windows® user interface facilitates the teach-in process at the color sensor and supports the operator in the task of adjustment and commissioning of the COAST sensor..

Software SPECTRO3-Scope (COLOR side):

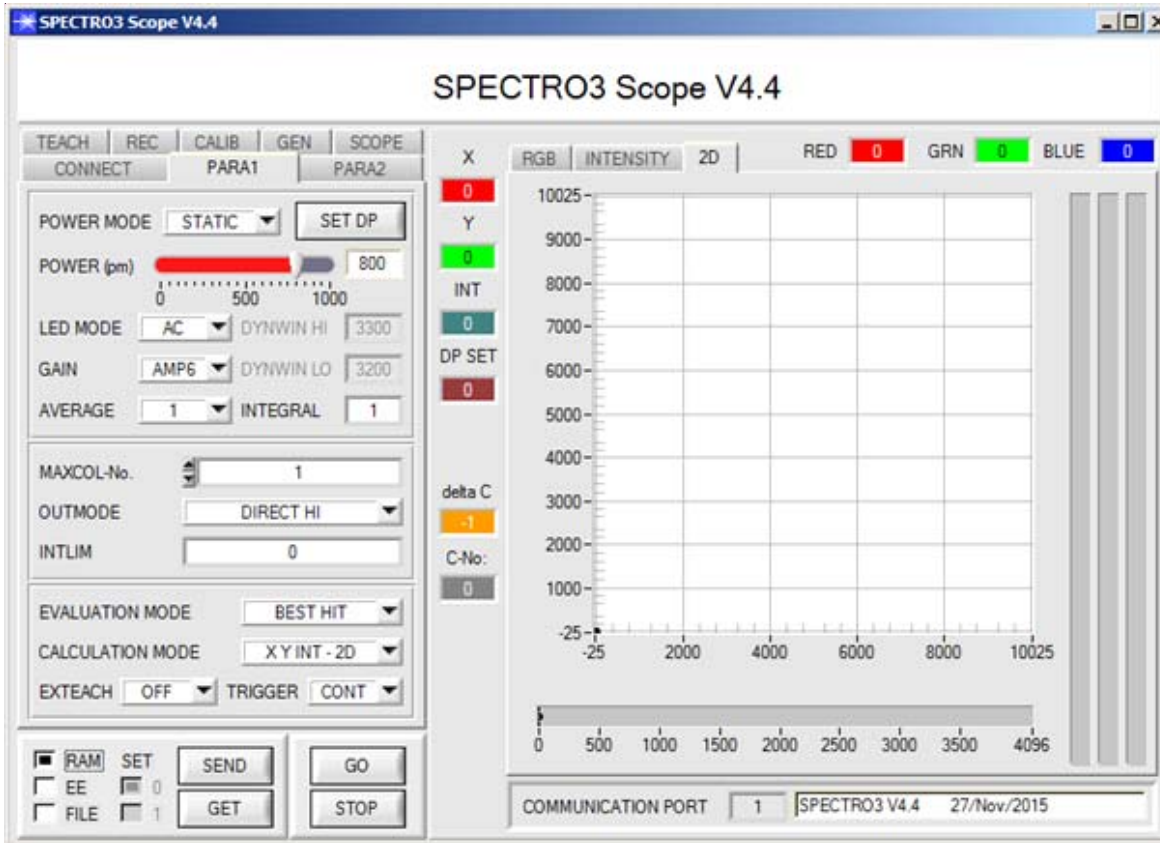

Under Windows® representation of the color value on a PC in numeric form and in a color chart, and representation of RGB values in a time chart. In addition the current RGB values are displayed as a bar chart.

The RS232 interface (tab PARA1 or PARA2) is used for setting parameters such as:

- POWER MODE: Light power of the LED
- LED MODE: Triggering of the internal light source
- GAIN: Used for setting the gain of the receiver
- AVERAGE: Averaging over a maximum of 32768 values
- INTEGRAL: This function field is used to set the number of scan values (measurement values) over which the raw signal measured at the receiver is summed up. This integral function allows the reliable detection even of extremely weak signals
- MAXCOL-No.: Number of colors to be checked
- OUTMODE: Triggering of the digital outputs
- INTLIM: Minimum intensity required for color evaluation
- EVALUATION MODE: Various evaluation modes to choose from (FIRST HIT, BEST HIT, MIN DIST, COL5, THD RGB)
- CALCULATION MODE: There are 2 methods of teaching a color, which are selectable via CALCULATION MODE. The CALCULATION MODE „X Y INT - 3D“ (or „s i M - 3D“) uses a color sphere in space with radius TOL. Contrary to this, the CALCULATION MODE „X Y INT - 2D“ (or „s i M - 2D“) uses a color cylinder in space with radius CTO or siTO and with height ITO or M. The teach process is the same for both methods. Color evaluation according to "s i M - 2D" uses the Lab calculation method.
- EXTEACH: In all the evaluation modes teaching of a color can be performed externally through IN0 or by means of the button at the sensor housing
- TRIGGER: Continuous or external or self trigger



Parameterization

Software STRUCT-Scope (STRUCTURE side): GENERAL-PARAMETER 1 and VIDEO & SPEC

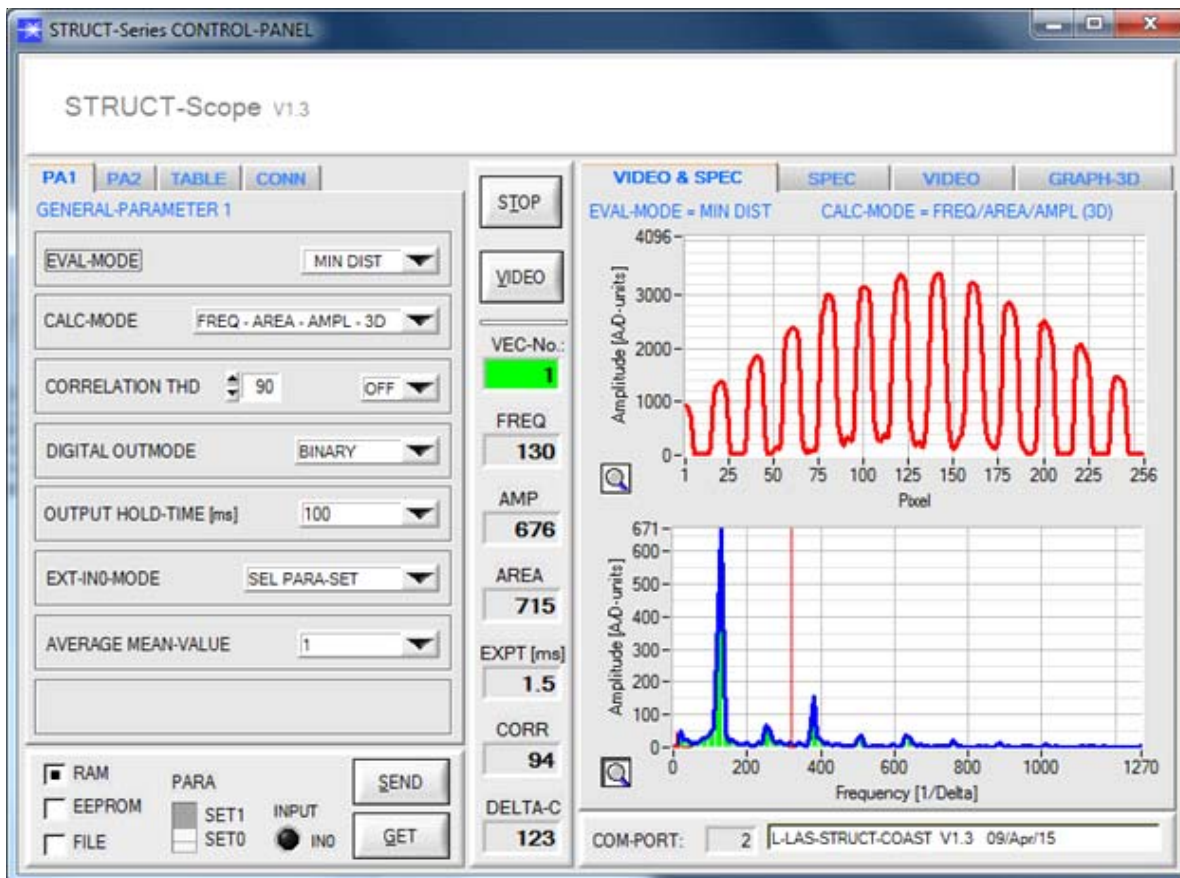

The RS232 interface (tab PA1, PA2 and TABLE) is used for setting parameters such as:

EVAL-MODE:	Evaluation mode in the 2D/3D number range
CALC-MODE:	Calculation mode of information from the spectrum
CORRELATION THD:	Threshold used in correlation calculation
DIGITAL OUTMODE:	Control mode of digital outputs
OUTPUT HOLD-TIME:	Output hold time
EXT-INO-MODE:	This list field is used to set the external trigger mode. (CONTINUOUS, TRIGG-INO L/H, TRIGG IN0 HIGH, SEL PARA-SET)
AVERAGE MEAN-VALUE:	This list field is used to set the averaging function sensor (possible values: 1, 2,4,8,16, or 32)



Parameterization

Software STRUCT-Scope (STRUCTURE side): TEACH-TABLE

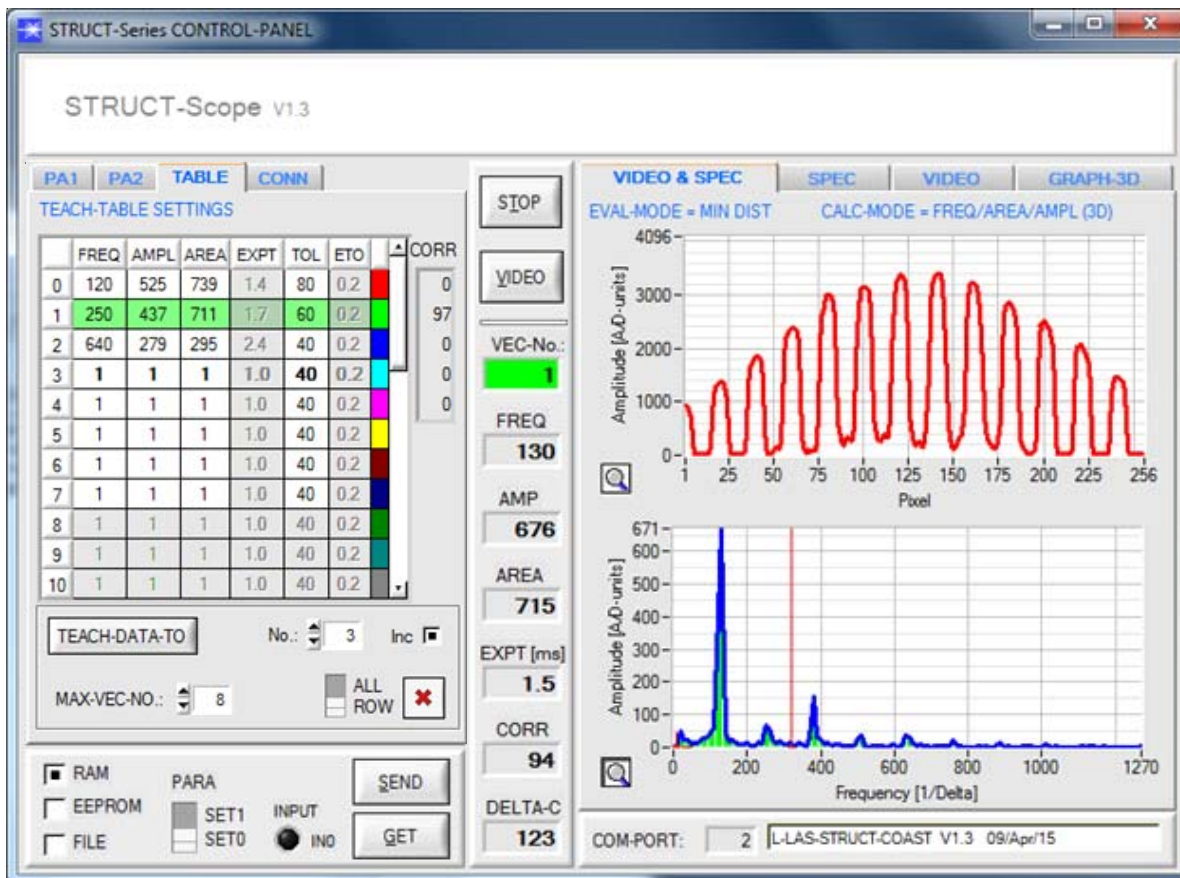

TEACH-TABLE:

Maximally 31 structure vectors (vector entries) for distinguishing 31 different structures, presetting of tolerances for the evaluation values (TOL) from the spectrum, and presetting of the tolerance for the exposure time (ETO).

Display of the correlation value for max. 8 comparison spectrums (spatial frequency spectrums).

TEACH-IN button for teaching the current spectrum to the teach table.

Display and input of the following evaluation values:

FREQ: Frequency
 AMPL: Amplitude/10 of the frequency spectrum
 AREA: Normed area ratio calculated from the frequency spectrum
 EXPT: Exposure time of the respective structure
 TOL: Tolerance for frequency and amplitude
 ETO: Tolerance for exposure time

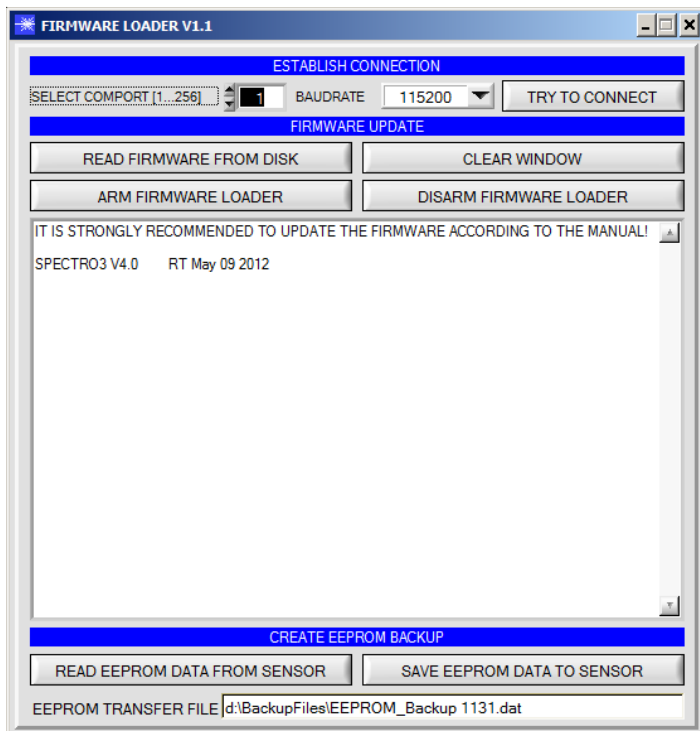
**Firmware Update****Firmware update by means of the software „FirmwareLoader“:**

The software „Firmware Loader“ allows the user to perform an automatic firmware update. The update will be carried out through the RS232 interface.

An initialisation file (xxx.ini) and a firmware file (xxx.elf.S) are required for performing a firmware update. These files can be obtained from your supplier. In some cases an additional firmware file for the program memory (xxx.elf.p.S) is also needed, and this file will be automatically provided together with the other two files.

**PARA Mode****Using forward and backward scattering of object surfaces in PARA mode:**

Some object surfaces are very hard to differentiate if only backward scattering is used.

If, however, forward scattering is used in addition, surfaces that have very similar colours but slightly different structures can be differentiated quite well.

Light is directed onto the surface at an angle of -45° and $+45^\circ$ from the normal (vertical). Only one light source is active at a time, which allows independent evaluation of forward and backward scattering.

For each sensor (color sensor and structure sensor) a specific parameter set is saved both for backward and forward scattering, i.e. altogether 4 parameter sets are available:

1. Parameter set (IN0 = 0) → Color sensor: Forward reflection
2. Parameter set (IN0 = 0) → Structure sensor: Backward reflection
3. Parameter set (IN0 = 1) → Color sensor: Backward reflection
4. Parameter set (IN0 = 1) → Structure sensor: Forward reflection