

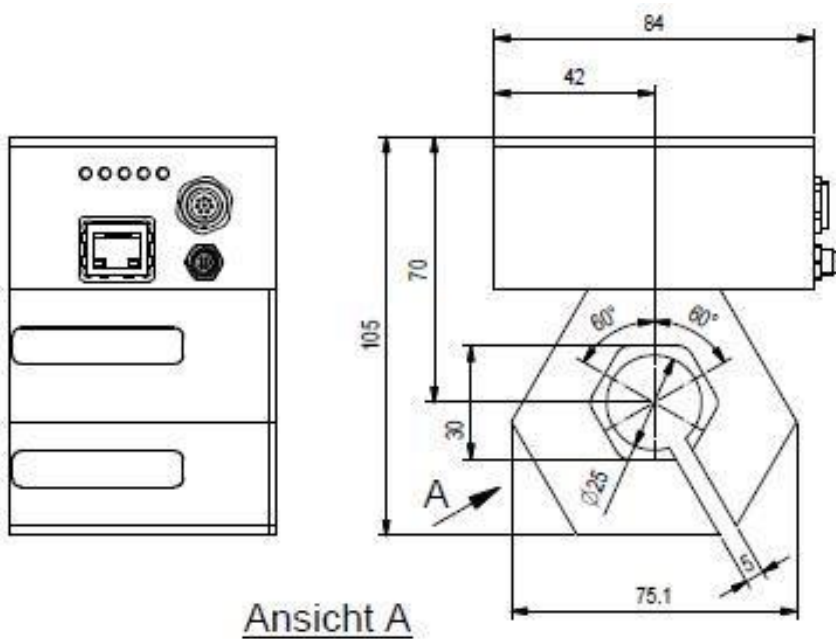

1. Laser light barrier: F-LAS-FOC-30-3x

The laser light barrier **F-LAS-FOC-30-3x** is equipped with a controller unit and comes with six laser light curtains, each with a 3mm x 0.2mm aperture. The laser beams are arranged in two planes, each with three laser light curtains. There is an angle shift of 120° between the laser beams in the plane, respectively. The sensor is prepared for detecting very small deviation of the ideal fiber, wire or thread like upstanding fibers, even at a very high speed of more than 10m/s. A RS232 as well as an Ethernet-connector is available.



Ansicht A

