

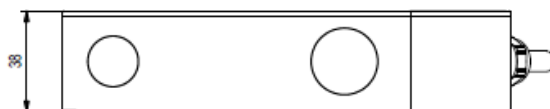

1. Optical fiber frontend type KL-D-45°/0°-85-1200-A3.0-VIS

The optical frontend type **KL-D-45°/0°-85-1200-A3.0-VIS** in connection with the color sensor type **SPECTRO-3-FIO-MSM-ANA-VIS** is used for color measurement tasks, especially in harsh environment with high temperature or Ex range.

It has to be pointed out, that the distance from the frontend to the object is 85mm and the spot size at this distance is elliptical and around 35mm x 25mm. Furthermore the system is working as a 45°/0° color measurement system and can be used especially in connection with flat gauge glass.

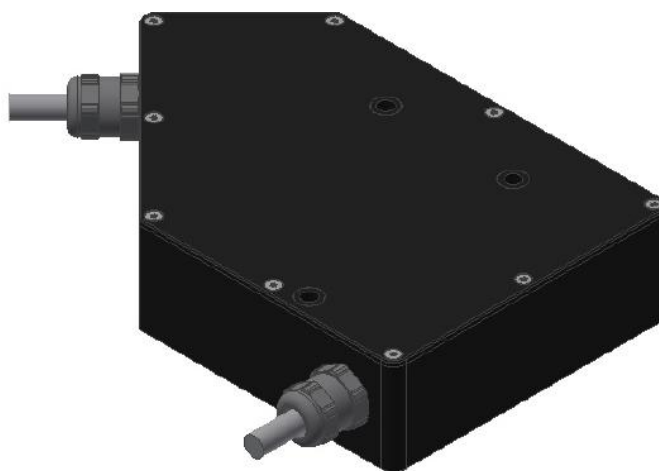
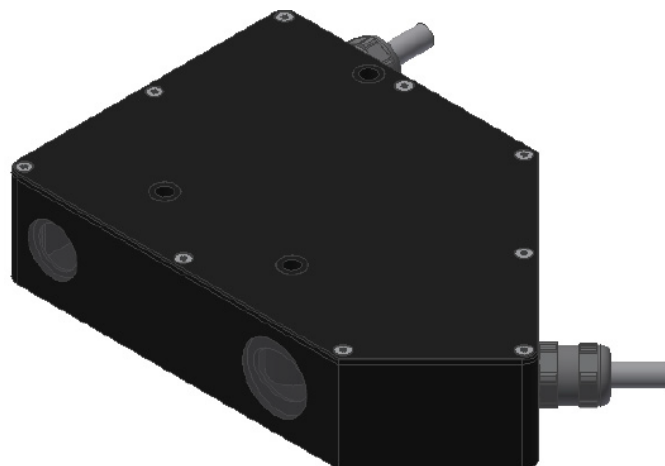

Empfänger
LWL R-S-A3.0-(3.0)-1200-67°-(1P+1BP)
Art.Nr.: 801882
ZNR.: 08000360

